



Government of Kerala

**MODIFIED GUIDELINES ON
SPECIFICATIONS, STANDARDS, UNIT COSTS, O&M PROTOCOLS,
SUBSIDY NORMS AND CONTRACT CONDITIONS FOR SOLID WASTE
TREATMENT PLANTS TO BE SET UP OR PROMOTED BY LOCAL
GOVERNMENTS USING VERMI COMPOSTING, WINDROW
COMPOSTING AND BIO METHANATION TECHNOLOGIES
(GO(MS) No. 73/2011/LSGD; dated 01-03-2011)**

**Local Self Government Department
Thiruvananthapuram**

CONTENTS

	Page No.
(i) G.O.(MS) No. 73/2011/LSGD; dt 01-03-2011	1
(ii) GUIDELINES	3

CONTENTS

1. INTRODUCTION	3
2. TECHNOLOGIES FOR TREATMENT ORGANIC FRACTION OF SOLID WASTE	3
2.1 VERMI COMPOSTING	3
2.1.1 Household Level Vermi-composting Units for 1.5 kg/day	3
2.1.2 Institutional level vermi-composting plant for 10-100 kg/day	4
2.1.3 Community level vermi-composting plants for 250 -2000 kg/day	6
2.2 COMPOSTING	12
2.2.1 Household level anaerobic composting units (1.5 kg/day waste feed)	12
2.2.2 Community level windrow composting plant of Capacity 1 – 10 tons/day	13
2.3 BIOGAS PLANTS	20
2.3.1 Household level	20
2.3. 1.a. Household level (Prefabricated -Low Cost Type) biogas plant	20
2.3.1. b. Household level floating dome type biogas plant for 7.5 kg/day (1m ³ capacity)	21
2.3.2 Institutional level biogas plant	22
2.3.2.a. Institutional level (Floating Dome Type) biogas plant	22
2.3.2. b Institutional level (Fixed Dome Type) biogas plant	24
2.3.3 Community level biogas plant	26
2.3.3. a Community level (Floating Dome Type) biogas plant	26
2.3.3.b Community level (Fixed Dome Type) biogas plant	31

3. SUBSIDY NORMS	36
4. GENERAL CONDITIONS	37
5. PAYMENT CONDITIONS	37
6. GUIDELINES ON MEMORANDUM OF UNDERSTANDING / O&M AGREEMENT FOR TREATMENT OF SOLID WASTES	
6.1. Format for memorandum of agreement for establishment of a solid waste treatment plant	39
6.2. Format for memorandum of agreement for operation & maintenance of solid waste treatment plant	42
7. ANNEXURES	46



Government of Kerala

Abstract

Local Self Government Department - Specifications, standards, unit costs, O & M Protocols, subsidy norms etc. for solid waste treatment plants to be set up or promoted by Local Governments using vermi-composting, windrow composting and bio-methanation technologies - Modified Guidelines - Approved - Orders issued

LOCAL SELF GOVERNMENT (DC) DEPARTMENT

GO(MS)No. No 73/2011/LSGD,

Thiruvanthapuram, 01-03-2011

- Read : 1) GO.(Rt) No.3498/07/LSGD dated 24.12.2007
2) G.O(MS) No.39/2008/LSGD dated 11.02.2008
3) GO(MS) No. 199/2008/LSGD dated 11-07-2008
3) Note from the Executive Director, Suchithwa Mission dated 23.02.2011

ORDER

As per GO read second above Government have issued detailed guidelines for specifications, O&M Protocols, unit cost, contract conditions, subsidy norms etc. for the technologies for processing of solid wastes. These guidelines were finalized based on the recommendations of a Technical Committee and rough cost estimates prepared and level of knowledge available at that point of time. It was the first attempt in the country in this kind.

Now three years has been completed since the implementation of the guidelines. It has become necessary to incorporate the lessons learned from the past three years and to address issues raised by the Local Governments. Accordingly modification of these guidelines were initiated by the Suchithwa Mission based on the detailed estimate of all civil works using PWD schedule of rates 2010. One sample layout plan, elevation and cross section of one size of plant each for all technologies, such as composting, vermi composting and biogas plants have also been prepared.

The draft modified guidelines prepared by the Suchithwa Mission was discussed in a Workshop conducted at Thiruvananthapuram on 7-12-2010, in which views and suggestions of experts in the field, service providers and accredited agencies were gathered. Based on the discussions necessary modifications were incorporated in the guidelines and thereafter got vetted by an Expert Committee constituted under the Chairmanship of Chief Engineer, LSGD.

The proposals for modification of the existing guidelines were approved by the State Level Coordination Committee for Decentralisation at its meeting held on 26-02-2010. Now in supersession of the GO read 2nd above and the paragraph 6 of the GO read 3rd above, Government are pleased to approve the modified guidelines as appended to this order on specifications, standards, unit costs, O& M protocols, subsidy norms and contract conditions for solid waste treatment plants to be set up or promoted by Local Governments using vermi-composting, windrow composting and bio-methanation technologies.

By order of the Governor

S.M. Vijayanand
Additional Chief Secretary

To

1. All Presidents/Secretaries of Village Panchayats
2. All Presidents/Secretaries of Block Panchayats
3. All Presidents/Secretaries of District Panchayats
4. All Mayors/Secretaries of Corporations
5. All Chairpersons/Secretaries of Municipalities
6. All Chairpersons of District Planning Committees
7. All District Collectors & Member Secretaries, District Planning Committees
8. The Chairman, Kerala State Pollution Control Board
9. The Member Secretary, Kerala State Pollution Control Board
10. The Director of Panchayats
11. The Director of Urban Affairs
12. The Commissioner of Rural Development
13. The Director of Public Relations (For immediate press release)
14. The Executive Director, Suchithwa Mission
15. The Chief Town Planner
16. The Director, Kerala Institute of Local Administration, Thrissur
17. The Executive Director, Kudumbashree
18. The Executive Chairman & Director, Information Kerala Mission
19. All District Planning Officers
20. All Deputy Directors of Panchayats
21. All Assistant Development Commissioners (General)
22. The Director, Local Fund Audit, Thiruvananthapuram
23. State Performance Audit Officer
24. General Secretary, Kerala Grama Panchayat Association
25. Secretary, Kerala Block Panchayat Association
26. Secretary, Chamber of Municipal Chairpersons
27. Secretary Chamber of District Panchayat Presidents
28. The Principal Accountant General (Audit), Kerala, Thiruvananthapuram (With C/L)

Copt to:

1. The Private Secretary to the Minister for Local Self Government
2. The PA to Additional Chief Secretary, Local Self Government Department
3. The PA to Secretary, Local Self Government Department
4. Local Self Government(DA/DB/DD/FM) Departments
5. Stock File/Office copy

Forwarded/By order

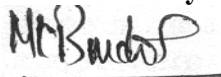

Section officer

MODIFIED GUIDELINES ON SPECIFICATIONS, STANDARDS, UNIT COSTS, O&M PROTOCOLS, SUBSIDY NORMS AND CONTRACT CONDITIONS FOR SOLID WASTE TREATMENT PLANTS TO BE SET UP OR PROMOTED BY LOCAL GOVERNMENTS USING VERMI COMPOSTING, WINDROW COMPOSTING AND BIO-METHANATION TECHNOLOGIES

1. INTRODUCTION

- 1.1 The solid waste management plants have been classified as Household level, Institutional level and Community level with different capacities under each category.
- 1.2. Guidelines on Specifications, Standards, Unit Cost and O&M protocols respectively for Vermi-composting, Windrow composting and Biogas plants are given in succeeding paragraphs.

2. TECHNOLOGIES FOR TREATMENT OF ORGANIC FRACTION OF SOLID WASTE

2.1 VERMI COMPOSTING

2.1.1. Household level vermi composting units for 1.5 kg/day

Infrastructure & Specifications

1. Two numbers of broad mouth plastic basin/ clay pots of 25 litre capacity each
2. Base layer with coconut fibre and gravel/sand with cow-dung (~5 kg) powder
3. Wire-mesh lid for the basins
4. 200 worms in each basin/pot
5. Holes at the bottom of the basin to drain leachate/vermi wash to a vessel if kept at below
6. Arrangements for protecting the basin from mouse, red ants etc
7. Thick wet cloth or wet sack piece for covering the waste
8. Surgical hand gloves for handling waste & manure
9. Vermi wash collection system is optional

Standards

1. *Eudrillus eugineae* worms
2. Moisture content of waste 40-55%
3. Temperature- 20 – 30°C

Unit cost

Rs. 800/- per unit

O&M Protocols

- 1 Chop the waste to size less than 5 cm before placing in the basin
- 2 Thickness of waste layer in the basin should not exceed 15cm

- 3 Use one basin for the first 15 days and then use the second basin after filling the first
- 4 Sprinkle cow-dung powder along with waste
- 5 Protect the basins from mouse, ants and other pests
- 6 Keep the basin covered with wet sack or cloth piece
- 7 Sprinkle water over the cover sack/cloth to maintain a moisture of 50-55%
- 8 Avoid over sprinkling of water and stagnation of liquid at the bottom of the basin
- 9 Basin should not be exposed to direct sun light or rainfall
- 10 Prevent introduction of excessive hot, sour and oily substances and also bones, meat & fibre Materials
- 11 For removing the vermi compost, expose the basin with contents in shaded sunlight for 2-4 hours and remove the compost from the top and use the basin with earthworms for further composting of biowastes
- 12 Compost taken out should not be dried under sunlight
- 13 Renew the base layer annually
- 14 Collection of wash out from the basin in the final stages of composting for vermi-wash

Maintenance cost

Rs.0.4 per kg of waste for small house-hold unit

2.1.2 Institutional level vermi composting plant for 10-100 kg/day

Infrastructure

1. Temporary shed with Angle iron /GI pipe structure and light roofing & cement concrete floor to accommodate the following:-
 - a) Waste reception/shredding sieving /packing bay for prepared compost etc.
 - b) Windrow bay area for treating the waste for a period of 15 to 20 days before placing the same in the vermi tanks.
 - c) Vermi pits(masonry tanks) of size 2mx 1mx 0.5m .Sufficient number of tanks to spread the waste of one month ,thickness of the waste spread above the base layer not to exceed 40mm. Bottom of the tank to have appropriate slope for ensuring leachate drainage
 - d) Tanks to be fitted with 50mm PVC pipe to drain out leachate to the leachate tank to be provided separately.
 - e) Leachate tank for collection of vermi wash
 - f) Electrical installations for lighting

2. Miscellaneous items

- a) Base layer with coconut husk of one or two layers with cow-dung powder
- b) 500 worms to be placed in each tank
- c) Plastic bucket/can for collection of leachate
- d) Washing area with water storage tank
- e) Arrangements for protecting the tanks from mouse, red ants etc
- f) Wet sack piece for covering the waste
- g) Cow-dung storage tank/bucket

- h) Surgical hand gloves for handling waste & manure
- i) Basket, Showel, Spade and Chopper, Gloves and Boots
- j) Manual 6 mm sieve with wiremesh fitted on wooden frame of size 1.2m x1m
- k) Spring balance
- l) Wire mesh cover on each vermi tank

Standards

- 1. *Eudrillus eugineae* worms
- 2. Moisture content of waste 40-55%
- 3. Temperature- 20 – 30°C

Specifications

Compost shed

- a. Shed of temporary structure with GI or angle iron truss with powder coated GI sheet roof of adequate size to accommodate the infrastructure listed .The size of the shed 30 sq.m for 10kg to 30 kg/day plant ,45 sq .m for 40 to 60 kg,70 sq .m for 70 to 80 kg ,90 sq .m for 90 to 100 kg/d plant.
- b. Vermi tanks: size and number of tanks as per 30 days requirement. For a tank size of 2m x 1m x (0.5m –height).2 nos for a 10 kg/ to 30 kg/day plant , 3 nos for 40 to 60 kg, 4 nos for 70 to 80 kg , and 5 nos for 90 to 100 kg plants.. Number of tanks depends upon the size of the tank selected. 50mm size PVC pipe of required length be provided ,under the floor for conveying the leachate to the leachate tank
- c. Leachate collection tank of volume 25 litre for 10kg/day plant .Higher sizes may be provided for higher capacity plants.
- d. Cowdung storage tank of 50 litre capacity for 10 kg/day plant. Size to be increased by 25 litre per increase of 10 kg for higher size plants.
- e. Electrical installation for lighting 1 CFL lamp for each for 12 m² shed area .External lights on the walls for area lighting.
- f. Two basket, One spade, one showel and one set hand gloves and boots for 10 kg/day to 40 kg/day plants and one wheel barrow, 4 baskets, 2 spades, 2 showels and 2 set hand gloves and boots for 50 to 100 kg/day plants
- g. Manual chopper for waste shredding
- h. Water storage of 40 litre for 10 kg/day plant. Size shall be increased by additional 20 litre per 10 kg increase for higher size plants.

Unit cost for plant, implements, utilities etc.in Rs lakh.

10- 30kg/d plants	40-60kg/d plants	70-80kg/d plants	90-100kg/ plant
1.8	2.6	3.9	5.0

O&M Protocols

1. Chop the waste to size less than 5 cm and place in windrow bays for a period of 15 to 20 days till the waste is ready for placing in the vermi tank .
2. Spread coconut husk layer along with cow dung powder at the bottom of the vermi tank .
3. The waste shall be spread over the base layers of coconut husk,after placing the worms on the base layer. Thickness of waste layer in the tank should not exceed 15cm at a time
4. Introduce fresh waste at consecutive portion of the tank or over the already spread layer on successive days
5. Sprinkle cow-dung powder along with waste
6. Protect the tank from mouse, ants and other pests
7. Keep the tank covered with wet sack or cloth piece
8. Sprinkle water over the cover sack/cloth to maintain a moisture of 50-55%
9. Avoid over sprinkling of water and stagnation of liquid at the bottom of the tank
10. Tank should not be exposed to direct sun light or rainfall
11. Prevent introduction of excessive hot, sour and oily substances. Bones, flesh & fibre materials can be placed as inter-layer within the soft waste layer
12. Heap the compost with worms within the tank under light for two days and remove the compost from the top and use the worms at the bottom for further composting
13. Stop watering 3-4 days prior to removing the vermi compost from the tank
14. Allow the compost to dry in shade prior to sieving
15. Compost should not be dried under sunlight
16. Renew the base layer annually
17. Engage a part-time labour for plant maintenance
18. Collection of wash out from the basin in the final stages of composting for vermi-wash

Maintenance cost

Maintenance cost per kg of waste ,plant capacity wise in Rs is given as below:-

10 kg/	20 kg	30 kg	40 kg	50 kg	60 kg	70 kg	80 kg	90 kg	100 kg
2.2	2.1	2.0	1.9	1.8	1.7	1.6	1.5	1.4	1.2

2.1.3 Community level vermi composting plants for 250 -2000 kg/day

Infrastructure

1. Shed of steel structure with light weight roofing and cement concrete flooring, of suitable size with PVC fencing wire mesh / net protection above 80 cm high parapet wall, on all sides to prevent birds, mouse, dogs etc ,to house the following provisions :-
 - a) Receipt/segregation platform 50cm high (raised floor) for spreading one day’s waste and segregating the non- biodegradable items if any

- b) Windrow compost bays each of 1.5 m to 2m width of required length to treat the waste for a period upto 20 days. Each bay to stack one day's waste .In smaller plants one bay may cater for more than one day'waste.
- c) Space for shredding.
- d) 28 numbers of masonry pits(tanks) having a width of 1m and depth 0.5 m and of sufficient length each to accommodate one days waste duly treated for a period of 15 to 20 days in the windrow compost bays. Bottom of the tank to have adequate slope to drain the leachate .A water channel of size 5cmx7cm around the vermi pits to prevent entry of ants.
- e) Adequate space around for the movements of men and materials
- f) Space for placing the sieve, storing the sieved manure, weighing machine, packing the manure in polythene bags and stitching the same
- g) Store with locking arrangements for storing 90 days production
- h) 50 mm PVC pipe under the floor to drain the leachate from vermi tanks to the draining channel and the draining channel below the floor level with cast iron removable covers flush with the floor, to drain the leachate that comes out from vermi tanks and windrow bays to the leachate collection tank
- i) Leachate collection tank of suitable size specified in Appendix A
- j) Lighting at the rate of 12W CFL per 12 sq.metre area

Other Miscellaneous items

- a) Office and rest room with toilet and wash area
- b) Water storage and supply system
- c) Cow dung storage tank
- d) Nursery tank for worms
- e) Septic tank with soak pit to treat leachate and the sewage
- f) Minor tools like, chopper, showels, spade, wheel-borrows, baskets, buckets -2 sets for 250 kg capacity and additional one set each for additional 250 kg capacity each.
- g) Surgical hand gloves and boots for staff-2 pairs each per staff.
- h) Coconut husk, cow dung, sack, cloth, wiremesh protection for vermin pits, Eudrillus eugineae worms

Mechanical equipments

- a) Shredder –manual for plants upto 500kg/d capacity and mechanical for 1ton/d capacity and above
- b) Bag sealing machine
- c) Platform balance
- d) Manual rotary sieve.
- e) Leachate pump

Standards

One windrow for each days' waste. In small plants waste be placed adjacently in the same bay on the subsequent days.

1. Windrow of width 1.5 to 2m height of 1.5 m and length to be adjusted to cater for one day's waste in bigger plants.
2. Waste be treated for fifteen to twenty days as required , in windrows before shifting to vermi beds.
3. *Eudrillus eugineae* worms 50 worms each per sq.ft area in each tank.
4. Moisture content of waste 40-55%
5. Temperature 20-30°C
6. In 250 kg/day plant, one vermi tank for 2 to 3 days' waste and in higher capacity plants one vermi tank each for one day's waste. Tank size and numbers specified in Appendix A

Specifications

1. Compost shed

- a) Foundation / basement: RCC column with RR masonry in cement mortar 1:6, 50 cm plinth height above average ground level filled up with approved earth/ red soil duly rammed in layers.
- b) Floor : with cement concrete 1:2:4 using 20 mm metal 75 mm thick and plastered with cement mortar 1:3 ,12mm thick one coat and finished smooth by hand trowel. Bottom of the vermi tanks will have the same specification of flooring. Platform surface will have a richer specification of 1:1.5:3 cement concrete.
- c) Wall : 80 cm high single brick wall all around. PVC fencing mesh of minimum thickness 2 mm and aperature not more than 30mmx30mm, on angle iron frame work over the wall upto the bottom of the tie beam(size 30cmx20cm to be provided between the columns on both the sides of the shed) on the sides and upto the roof level on the front and backsides to prevent birds ,mouse etc..
- d) Roof : 0.25 mm thick powder coated sheets over angle iron trusses and purlins. Slope on two sides with side height 3.2 metre above the plinth level. Half cut PVC 110 mm dia pipes /suitable gutter along the eve edge with proper slope and adequate number of down pipes 110 mm PVC to drain the rain water.
- e) Doors : On the front wall , a double shutter hinged door of suitable size (3m x2.8m) with a ramp for unloading waste from the vehicle into the receipt platform. And a normal door of size 1.2m wide and 2.1 m height for movement of men and other materials in and out of the shed .
- f) Store : in one corner of the shed and the outer walls of the shed on the store side be constructed with bricks instead of PVC mesh. Internal partition between the shed area and the store with 2.5 metre brick wall and PVC mesh on angle iron frame work above the wall.Ventillators on the outer walls

- g) Vermi (tanks)pits: Brick work and cement plastering with 1:3 cement mortar, Total depth of the pit of 50 cm, 40 cm above the finished floor level and 10cm below the finished floor level The concealed PVC pipe embedded inside the floor will connect the leachate flow with the leachate channel all around. Sufficient space around the tanks (pits) for easy access. A water channel of size 7 cm x 5cm around the pits to prevent ants.

Note: Typical layout and sectional elevation of a compost shed ,given as Sketch Nos 1 and 2 for guidance. Certain construction details are given in Sketch No 2A. Arrangements for collection of leachate from the pit to the leachate channel is given in Sketch No3. A model layout of a vermi compost plant appended as Sketch No 4 gives ideal locations of various components of a vermi compost plant . Sizes of individual components of the vermi compost plants of capacities 250 ,500 ,1000 , and 2000 kg/day plants are given in Appendix.A as infrastructure requirements . Shed for nursery tank and the cow-dung tank

In the plant layout given , cow-dung tank and nursery tank are placed inside another temporary open (sides) shed made with GI pipe and powder coated GI sheet roof.

2. Office cum rest room

An office space of appx 3mx3m area and workers restroom of appx 3mx3m area along with one toilet each for men and women ,a wash room for women in the same block for the plants of capacities 1000 kg/day to 2000 kg/day. Typical layout of office cum rest room is given in the Sketch 5. In case of smaller plants of 250 kg/day and 500 kg/day a single room of size 3mx3m with toilet and wash room as office cum rest room .Random rubble masonry foundation , brick wall, and RCC slab roof construction.

3. Guard room /gate

A guard room of size 2.1mx 2m area at the entrance to the plant compound for watch and ward in case of 1000 kg and above capacity plants. In case of smaller plants guard can use the office cum rest room during night hours. Gate fabricated out of MS grill duly painted mounted on gate pillars

4. Electricity

An LT connection from EB ,distribution board/meter box in a weather proof feeder pillar box mounted on a pole inside the compound , service connections to all the buildings .Sufficient security lights with flourascent/ CFL lights on the outer walls of the buildings with brackets . Post top lantern lights on the gate pillars .Street lights on poles where considered necessary.

5. Water supply

A 1000 litre capacity PVC water tank above the roof of office cum rest room upto 1 ton capacity and 2000litre tank for 2 Ton plant..Ground sump and monobloc pump where required.

6. Roads /compound wall

Roads with width of 3m and side berms 50 cm each on both sides and a compound wall with random rubble masonry foundation and cement concrete blocks to a height of 6 ft as required at site and the cost be added separately. Typical layout of a vermi compost plant showing the vermi shed, office cum rest room wash areas, cow-dung cum nursery tank shed, guard room, roads and green belt given in Sketch No 4.

7. Green belt

A green belt of minimum width of 3 m be provided all around the plant compound inside the walled area. It is recommended to plant “ Mahagony “plant on the outer row, Bamboo/ Aryaveppu on the second row and flowering plants/ shrubs like Chemparathi/Arali/Mandar /Mulla be planted on the third row and maintained to increase the aesthetic value of the plant complex.

8. Rain water harvesting

Rain water harvesting as per norms as an optional item

9. Equipments/Machineries

- a) Shredder : Manual shredder for plants upto 500 kg/day and mechanical one for plants of 1 ton and above
- b) Leachate pump A sludge pump with open impeller 1 hp portable on wheels to pump out the leachate from the leachate collection tank.
- c) Sieve : A manually operated rotary sieve suitable to pass upto 6 mm size particles
- d) Weighing Machine: A platform weighing machine range upto 300 kg.
- e) Bag sealing machine ;A portable bag stitching/ sealing machine operating on single phase 230 V supply for sealing the filled up bags

Unit cost of plants, machineries, utilities etc in Rs lakh is as under:-

250kg/d plant	500 kg/d plant	1000 kg/d plant	2000 kg/d plant
11.4	14.5	26.0	39.3

Notes

1. The cost prepared based on Kerala PWD SOR-2010 for the model lay-out.
2. The specifications and estimates are based on design suitable for normal ground conditions with “all soils”. (a mix of ordinary soil and hard soil in the ratio 50:50) and moderate wind conditions. Any change in these conditions may involve changes in the specifications and the cost. Such changes to be verified by a technical team and the estimate be prepared as per PWD SOR and technically got approved from the competent authority.
3. The estimate quoted above include the cost of the complete vermi plant complex, including the cost of equipments and utilities , but excluding the cost of land, boundary wall ,road and rainwater harvesting .Costs of these items depend upon the site conditions Further breakdown details are given in Appendix B
4. Cost include contractors’ profit but doesn’t include statutory works /service tax
5. Lay-out plan given are for guidance, the same can be modified to suit the local site conditions.

O/M Protocols

1. Segregate the waste on receipt and cut over size items to size of less than 5cm either manually or by using a shredder machine .Remove and dispose off the non-biodegradable waste for recycling /final disposal.
2. Treat the waste initially in windrows for a period of 15 to 20 days or more as per the nature of the waste. Height of stack not to exceed 1.5 m in windrows. Windrows shall be turned once in four to five days to the next bay and break the windrows when ready for feeding to vermi tanks.
3. Base layer with coconut husk for one or two layers with cow dung powder be placed in the vermi tanks.(This layer be renewed annually).Place the worms on the base layer and the partially decomposed waste from the windrows be spread over it .
4. Thickness of waste layer should not be more than 30cm at a time . Sprinkle cow dung mix on the waste and moisture content shall be maintained as 40 -55%
5. Introduce fresh waste in the consecutive portion of the same tank /consecutive tanks on successive days.
6. Sprinkle cow dung powder along with the waste
7. Protect the tank from mouse, rats and ants by covering with a PVC coated net bend to shape and welded to an aluminium/steel frame with a handle.
8. Keep the waste covered by wet clothes/sack pieces. Moisture contents of the waste to be maintained as 40- 55% by sprinkling water over the cloth. Temp shall be in the range 20-30C.
9. Avoid over sprinkling of water and stagnation of water at the bottom of the tank
10. Tank should not be exposed to direct sun or rainfall.
11. Prevent introduction of excessive hot, sour, and oily substances. Bones, flesh & fibre can be placed as interlayer within the soft waste layer.
12. Heap the compost with worms within the tank under light for two days and remove the compost from the top and use the worms at the bottom for further composting
13. Stop watering 3-4 days prior to removing the compost from the tank
14. Allow compost to dry in shade prior to sieving.
15. Compost taken out should not be dried under sunlight.
16. Renew the base layer annually.
17. Engage appropriate no of labourers for operating the plant
18. Collection of washouts from the tank in the final stages of composting for vermi wash.

Maintenance cost

Maintenance charges plant wise given as under in Re

250 kg/d	500 kg/d	1000 kg/d	2000 kg/d
0.45 /kg	0.40/kg	0.38/kg	0.30/kg

Notes:

1. Maintenance cost is including all expenditure such as wages of the staff, electricity charges or any other incidental expenditure involved in running of the plant and will be payable per kg of the waste handled.
2. Compost produced will be the property of the operator.
3. Watch and ward and all type of routine maintenance of the infrastructure including the green belt will be the responsibility of the operating agency.

2.2 COMPOSTING

2.2.1 Household level anaerobic composting units -1.5 kg/day waste feed (Ring composting unit)

Infrastructure

1. Two sets of circular ferro - cement rings resting on circular ferro - cement slabs and covered by another circular ferro - cement slab with provision for loading the waste from the top and removing the compost from the bottom ,when ready.
2. Base layer with cow-dung (~5 kg) powder
3. Surgical hand gloves for handling waste & manure

Specifications

1. Ferro- cement ring of internal diameter 0.7 m ,thickness 2.5 cm and height 0.5 m placed over a circular ferro-cement slab of dia 0.75m and thickness 2.5 cm (without fixing).The ring to have a 30cmx30cm opening on the side at the bottom with a ferro-cement slab cover of the same curved shape which can be removed and refitted back tightly with a locking arrangement for removal of compost when ready. The ring will also have a hole of dia 2.5cm at the bottom for the leachate to flow out.
2. Circular ferro- cement cover slab of 0.75 m diameter and 2.5 cm thick with central circular hole of 0.30 m diameter to cover the ring. The hole will have a lid cover which can be removed and refitted back for loading the waste into the ring and closing it tightly after loading the waste.
3. Sketch no. 5 A gives the details of a composting unit.

Standards

1. Moisture content of waste 40-55%
2. Temperature- 20 – 30°C

Unit cost

Rs. 1800/- per unit

O&M Protocols

1. Chop the waste to size less than 5 cm before placing in the basin
2. Remove the top central lid cover of the ring and drop the waste inside the ring
3. Spread the waste evenly in within the ring
4. Use one ring for the first 90 days and then use the second basin after filling the first
5. After 175 days, compost from the first ring can be emptied from the side opening and the ring can be used for further waste feeding
6. Renew the base layer annually

Maintenance cost

Rs.0.1 per kg of waste for small households

2.2.2 Community level windrow composting plant of Capacity 1 – 10 tons/day

Infrastructure

1. Compost shed

Shed of steel structure with light weight roofing, cement concrete flooring, of suitable size, PVC mesh protection over 80 cm parapet wall, all around to prevent entry of birds, dogs etc with the following provisions:-

1. Receipt/segregation platform 50 cm high (raised floor) to spread one day's waste and to remove all non biodegradable items.
2. Space for manual shredding/placing a shredding machine to cut over size waste into sizes less than 75mm size.
3. Space earmarked for windrows -25 nos each 2 m wide and of sufficient length to stack one day's waste.
4. Adequate space around to move a trolley to turn the waste once in 5 days from one windrow bay to another and then to the maturity bay on the 25th day.
5. Maturity bay for stacking min 30 day's partially treated waste from the windrows
6. Space for placing a rotary manual/motorised sieving machine, weighing machine, packing the manure in bags and stitching the same
7. Storage space with locking arrangements to stack min 90 days' production.
8. Provision of an RCC channel with adequate slope under the floor with cast iron / RCC cover flush with the floor for draining the leachate to the leachate collection tank. provided. Flooring on the bays with slope so that leachate flows in one direction and gets collected in one corner of the bay and then flows into the leachate channel provided next to the bay through an opening under the leachate channel cover.
9. Leachate collection tank of suitable size
10. Electric wiring and lighting to ensure proper lighting to the shed at a rate of one CFL 15 W per 12 sq.metre area/power to the equipments.

2. Miscellaneous items to be provided outside the compost shed.

- a. Rest room and Office room with Toilet and wash area.
- b. A temporary shed open on sides, with cow dung storage tank, and anaerobic composting bays for treating slowly decomposing biodegradable wastes and space for temporarily stocking the non-biodegradables for a week till disposal.
- c. Guard room
- d. Water supply tank and plumbing arrangements., rainwater harvesting tanks.
- e. Wheel barrow with pneumatic wheels, basket showels, spade, sorting tool, chopper, polythene bags 50 lit capacity 2nos each for 1 ton plant and one each extra for additional two ton capacity each.
- f. Surgical hand gloves, and gun-boots masks two pair per labourer.
- g. Septic tank (having a volume of 2 m³ per ton capacity) and soak pit for treatment and disposal of leachate.

3. Mechanical Equipments

- a. Shedder -manual for plants of capacity upto 2 ton/d and mechanical for plants of capacity higher than 2 ton/d
- b. Rotary sieves -manual for plants of capacity upto 2 ton/d and motorised for plants of capacity higher than 2 ton /day.
- c. Platform balance
- d. Stitching machine
- e. Slurry pump

4. The following mechanical equipments be provided in higher size plants as optional Items

- a. Conveyor belt at the receipt bay for segregation and convey of waste to the shedder. (6 ton and above)
- b. Window turner tractor mounted front loader (11 ton and above)

Standards

1. Use of special steel wherever applicable
2. ISI marked roofing, electrical, and PVC items and energy saving motors be used where available.

Specifications

1. Compost shed

- a. Foundation / basement: Reinforced concrete column with random rubble masonry in cement mortar 1:6, 50 cm plinth height above average ground level filled up with approved earth /red soil duly rammed up in layers and compacted.

- b. Flooring : Cement concrete 1:2:4 with 20mm metal 75 mm thick , Plastered with cement mortar 1:3 ,12mm thick one coat and finished smooth by hand trowel. Adequate slope on the floor in windrow bays to enable leachate to flow into the leachate draining channel provided . Leachate draining channel be rounded of at the bottom corners .The minimum cross section of the channel at the starting point be 100x100mm and depth to increase as it progresses further to provide adequate slope for the leachate to flow and width be increased upto 300 to 350mm for easy cleaning of the channel. The leachate collection channel to be provided with perforated CI duct covers/RCC cover ,flush with the floor. The duct covers be of suitable length provided with counter sunk handle for easy removal for cleaning of the channel
- c. Walls : 80 cm high single brick wall all around side covering with ,PVC fencing mesh of minimum 2mm thick and maximum mesh size 30mmx30mm on angle iron framework over it upto tie beam(size 30cmx20cm to be provided on both the sides between the columns on the top) level on the sides and to the roof level on front and backsides of the shed. Minimum height of the shed over the column shall be 4.5 m above plinth level.
- d. Roof : 0.25 mm thick powder coated GI sheets over angle iron trusses and purlins. Slope on two sides with height on the wall side 4.5m above the plinth level. Half cut PVC 110 mm dia pipes /suitable gutter along the eve edge with proper slope and adequate number of down pipes 110 mm PVC to drain the rain water .
- e. Doors : On the front wall a double shutter hinged door of suitable size (3m x2.8m) with a ramp for unloading the waste from the vehicle into the receipt platform. And a normal door of size 1.2m wide and 2.1 m height for movement of men and materials in and out of the shed .
- f. Store : In one corner of the shed, the outer walls of the shed on the store side be constructed out of bricks instead of mesh. Internal partition wall between the store and the shed be of height 2.5 metre with PVC mesh on angle frame work over 2.5m high walls. Ventilators on outer walls. In case of plants of 6 tons and above store room be planned in a separate shed adjascent to the packing bay.

Note:-Typical layout and the sectional elevation/structural details of a windrow compost shed, given as Sketch Nos 6 and 7 for guidance. Certain construction and foundation details are given in Sketch No 2A. Model layout of a windrow plant appended as Sketch No 9 . Sizes of individual components of the windrow plants of capacities 1 to 5 ton per day and 6 to 10 tons per day are given in Appendix C.

2. Shed for cow dung tank, anaerobic bays and non biodegradables:

In the plant layout given, the cow-dung tank and anaerobic bays are placed inside another temporary open shed made of GI pipe roof and powder coated GI sheet roof. Anaerobic bays to cater for slow decaying bio-degradable waste of approximately 5% of the daily waste input for a period of 90 days.. For plants of 2 ton and above provide twelve bays each of adequate size worked out based on a week's requirement and for 1 ton plant provide six bays each

bay to cater for two weeks' requirement each. Total number of anaerobic bays for 90 days' storage. The anaerobic bays are covered on three sides with front side open. Floor with sloping towards entrance side and the leachate generated to flow through an RCC channel and get disposed into the leachate pit. Sketch No 8 gives a typical layout of an anaerobic shed. Provide one bay of sufficient capacity for storing the cow-dung and one bay for storing the non-biodegradables that get separated from the waste for a week till these are disposed off to a shredding plant /recycling /land fill area.

3. Office cum rest room with washing area

An office space of appx 3mx3m and workers rest room of appx 3mx3m along with one toilet each for men and women, a wash room for women in the same block for the plants of capacities 3 ton/day to 5 ton/day typical layout is given in the Sketch No 5. In case of 1 ton and 2 ton plants one rest room with two toilets. And for higher size plants (ie) 6 ton size and above additional 10 sq m of rest room area per 5 ton of additional capacity each. Separate buildings for office and rest room in higher size plants. Random rubble masonry foundation, brick wall, and RCC slab roof construction.

4. Guard room /gate

A guard room of size 2.1mx 2m at the entrance to the plant complex for watch and ward staff in plants of capacity 3 ton and above. No guard room for smaller size plants upto 2 ton capacity. Gate fabricated out of MS duly painted mounted on gate pillars.

5. Electricity

An LT connection from EB, distribution board/meter box in a weather proof feeder pillar box mounted on a pole / on the shed/ on the ground inside the compound, service connections to all the buildings, by means of weather proof/ under ground cables. Sufficient security lights with fluorescent / CFL lights on the outer walls of the buildings with brackets. Post top lantern lights on the gate pillars. Street lights on poles where considered necessary.

6. Water supply

A 1000 litre water tank for plants 1 ton and 2 tons capacities 2000 litres upto 5 ton /day capacity plant, above the roof of office cum rest room. Additional 1000 litres capacity per increase of 2 Ton. Separate staging for water tanks in higher size plants. Ground sump and monobloc pump where required. Garden taps on all the four corners and centre with stand post. 100 m PVC hose for gardening.

7. Rain water harvesting

PVC pipes 110 mm dia to be laid to connect the down pipes of the windrow shed to connect to the rain water tanks /recharge pits.

8. Roads /compound wall

Roads, having width of 3m and side berms 50 cm each on both sides and a compound wall with random rubble masonry foundation and cement concrete blocks to a height of 6 ft as required at site and the cost be added separately. For Typical layout of a windrow plant showing the windrow shed, office cum rest room wash areas, cow-dung cum anaerobic tank shed, guard room, roads and green belt please refer Sketch No 9.

9. Green belt

A green belt of minimum width 3 m be provided all around the plant compound inside the walled area. It is recommended to plant “ Mahagony “plant on the outer row, Bamboo/ Aryveppu on the second row and hedges on the inner row. Flowering plants like Chemparathi/ Arali/Mandar /Mulla can also be planted on the third row and maintained to reduce the pollution nuisance and increase the aesthetic value of the plant complex.

10. Equipments/Machineries

- a. Shredder : Manual shredder for plants upto 2 ton and mechanically operated shredder in plants capacity higher than 2 ton to cut the waste of sizes larger than 75 mm
- b. Leachate pump : A sludge pump with open impeller 1 hp on portable platform to pump out the leachate from the tank along with a flexible hose
- c. Sieve : A manually operated rotary sieve suitable to pass upto 6 mm size particles for plants upto 2 Ton capacity and motorised sieve for plants of above 2 Ton capacity
- d. Weighing Machine: A platform weighing machine range upto 300 kg
- e. Bag sealing machine: A portable bag stitching/ sealing machine operating on single phase 230 V supply for sealing the filled up bags

Unit cost for plant,implements, utilities etc

Cost worked out as per the norms given in these guidelines, capacity(ton per day) wise in Rs lakhs are as under:-

1 ton	2	3	4	5	6	7	8	9	10
14.9	20.2	29	35.3	39.7	50.3	55.3	60.4	64.7	70.7

Notes

The cost given are based on Kerala PWD SOR 2010 for the model layout .

1. The specification and the costing has been drafted in these guidelines based on design suitable for normal ground conditions with “all soils”(a combination of ordinary soil and hard soil in the ratio 50:50)and moderate wind conditions. Any change in the these conditions may involve changes in specification and the cost. The changes in the design due to site conditions be certified by a technical team and priced as per PWD SOR and technical sanction got issued from the competent authority.
2. The estimate quoted above include the cost of the complete windrow plant complex , including the cost of equipments, utilities etc, but excluding the cost of land , boundary wall, road , rainwater harvesting and development of sources in respect of electricity and water and costs of these items depend upon the site conditions . Further breakdown details are given in Appendix D
3. Cost include contractors’ profit but doesn’t include statutory works /service tax
4. Lay outs given are for guidance . It can be modified to suit the site requirements
5. Sizes of various components of the plants for various capacities are listed in Appendix C as infrastructure requirements.

6. Cost of boundary wall with RR masonry foundation and concrete block height upto 2 m be taken as Rs 1500/-per RM
7. Cost of road with two layers of 100 mm metalling with 20mm carpetting be taken as Rs 1780 per 10 sq.metre.

O&M Protocol

1. Receive the waste in receipt area and spread it on the segregation platform
2. Pick up the non bio degradables if any and send the same for further disposal. Pick up the bigger size degradable items (> 75mm) and load the same into the shredder to reduce the size to less than 75mm. In smaller plants(upto 2 Ton capacity) shredding be done manually .Use mechanical shredder in plants of capacity 3 Ton and above.
3. Move the bio- degradable waste ,including the shredded waste into the first windrow bay
4. Mix the waste with cow-dung slurry or dust depending upon the moisture content of the waste and form the window.
5. Regulate the windrow to max 2m width and height 1.5 m
6. Turn the windrow to another bay once in 5 days and fill up the first windrow with the fresh waste. Form one windrow exclusively with one day's waste.
7. Maintain the temp inside the windrow between 55 to 60⁰ C for three days to destroy the pathogens and between 50-55 C for rest of the period for max microbial activity. Monitor the temp with in the windrow by changing the turning frequency of the waste.
8. Sprinkle leachate over each windrow for maintaining the moisture of 55%
9. Break the windrow and spread it for secondary sorting and moisture reduction on the 25th day.
10. Send the sorted non-biodegradable to recyclable bag and slow putrifying waste to anaerobic composting bay.
11. Sieve the compost and move the output to the designated maturity yard and keep it in a heap of 3m for a period of 30 days or till the compost is fully matured.
12. The fully matured compost be packed in plastic bags duly weighed and stitched. The stitched bags be shifted to store and stacked for further disposal.
13. Drying of compost under direct sunlight is undesirable
14. Recover the waste subjected to anaerobic composting tank, apply deodorant and add it to the windrows for aerobic composting
15. Make arrangements for disposing off recyclable waste collected in polythene bags
16. Avoid over sprinkling of leachate or water to the windrow and prevent stagnation of any liquid in the composting yard
17. Stop sprinkling of water 2-3 days prior to breaking the windrow
18. Prevent any obstruction to the drainage of leachate and collect it in the designated tank

19. Ensure that there is no leakage of leachate to surface or groundwater sources
20. Overflow of leachate tank to be directed to a septic tank and then to a soak pit
21. Cover the leachate tank securely to prevent mixing with rainwater
22. Maintain cow-dung storage for one month
23. Store an appropriate quantity of saw dust or dry leaves for application to high moist waste
24. Labour requirement for 1-10 tpd plant vary from 2-10. Engagement of a Supervisor is optional for improving quality control
25. Biological odour management by maintaining optimum moisture, temperature and aeration is critical
26. Maintaining temperature of 55-60°C for 2-3 days is critical for removal of pathogens and parasites
27. Ensure the compliance of worker protection safeguards through the use of gloves, gum boots, masks etc and maintenance of personal hygiene
28. Subject the compost to physico-chemical test periodically for nutrient content, organic content, pH, texture, particle size distribution, moisture content, moisture holding capacity, slat concentration, degree of stabilization, presence of pathogenic organisms, concentration of heavy metals to ensure quality and take precaution from health hazards

Maintenance cost

Operation and maintenance cost per kg of waste handled given as under for different capacities of the plant in Paise

1 ton	2 ton	3 ton	4 ton	5 ton	6 ton	7 ton	8 ton	9 ton	10 ton
30	28	27	26	25	24	23	22	21	20

Notes:-

1. The maintenance cost to include payment of wages, electricity charges and all other incidental expenditure in running, watch and ward and upkeep of the plant including the maintenance of the green belt.
2. The rejects are to be disposed off in the best eco-friendly way possible depending upon the location.

2.3 BIOGAS PLANTS

2.3.1 Household level Bio gas plant

2.3.1 a. Household level (Prefabricated -Low Cost Type) biogas plant

Infrastructure & Specifications

1. Treatment capacity – 2.5 kg of solid waste per day
2. Volume of digester including gas holder - 0.50 m³
3. PVC tank with circular shape as digester and gas holder
4. Inlet device with PVC pipe of diameter 110 mm
5. Inlet chamber with a plastic mug having circular shape and with a lid.
6. Outlet device with PVC pipe of 63mm
7. A plastic can of 10 liter capacity to be used for collecting slurry/effluent for safe disposal. If toilet waste is also treated in biogas plant, slurry from biogas plant to be treated in a septic tank soak pit arrangement.
8. Rubber hose of 25 mm (³/₄ inch) diameter for conveyance of biogas for use with a maximum length of 10 m
9. Stove with single burner
10. Control valve for regulating gas

*Plant to be established in a place fully exposed to sunlight and away from drinking water source.

Standards

1. Minimum waste retention time of 40 days
2. All PVC pipe of class 4 kg/cm²
3. Rubber hose, stove and control valve with ISI mark
4. Particle size of waste not to exceed 20 mm

Unit cost

Rs.6,500/-

O&M Protocols

1. Start up by adding 25 kg of cow dung with equal quantity of water
2. Waste feeding after chopping and mixed with water in the ratio 1:1
3. Daily feeding of easily degradable waste in slurry form or solid waste mixed with equal quantity of water (rice water or other kitchen waste water used for washing of rice, vegetables ,meat etc is preferable) Clean the inlet chamber after each feed and keep
4. Limit the maximum quantity of daily feeding of waste.
5. Daily removal of slurry in plastic cans and disposal as manure / disposal in to septic tank and soak pit arrangement.
6. Prohibited to feed the wastes of slow degrading nature like straw, soil, egg shells, fibrous materials like banana leaves, coconut shells, coconut coir , pseudo stem etc .Feeding of toxic substances like fungicides, insecticides, pesticides, detergents and disinfectants like phenyl, dettol etc. are also prohibited.
7. Mix the substrate or rotate the drum at least weekly for preventing scum formation

Maintenance cost

Rs. 200/- annum per unit

2.3.1.b Household level floating dome type biogas plant 1m³ capacity

Infrastructure & Specifications

1. Treatment capacity – 7.5 kg of solid waste per day
2. Volume of digester(including gas holder) - 1 m³
3. Digester -PVC tank circular shape
4. Gas holder dome PVC/ Fiber Reinforced Plastic (FRP).
5. Central support of GI pipe of 40 mm (medium class), fixed to a steel frame work to act as guide for the dome to move up and down
6. Inlet device with PVC pipe of diameter 110 mm
7. Inlet chamber with plastic container, having circular shape of 30 cm diameter and with a lid.
8. Outlet devise with PVC pipe of 63mm diameter.
9. A plastic can of 10 liter capacity to be used for collecting slurry/effluent for safe disposal. If toilet waste is also treated in biogas plant, slurry from biogas plant to be treated in a septic tank soak pit arrangement.
10. Rubber hose of 25 mm (¾ inch) diameter for conveyance of biogas for use with a maximum length of 10 m
11. Stove with single burner
12. Control valve for regulating gas

*Plant to be established in a place fully exposed to sunlight and away from drinking water source.

Standards

1. Minimum waste retention time of 40 days
2. All PVC pipe of class 4 kg/cm²
3. Medium class GI Pipe for central support
4. Rubber hose, stove and control valve with ISI mark
5. Particle size of waste not to exceed 20 mm

Unit cost

Rs.10, 000/- (without septic tank and soak pit)

O&M Protocols

1. Start up by adding 50 kg of cow dung with equal quantity of water
2. Waste feeding after chopping and mixed with water or part of waste water in the ratio of 1:1
3. Daily feeding of easily degradable waste in slurry form or solid waste mixed with equal quantity of water. Rice water, other waste water used for washing of rice, vegetables or meat in the kitchen be used in place of water.
4. Limit the maximum quantity of daily feeding of waste to 7.5 kg/ day. A plastic can to be used for collecting slurry/effluent for safe disposal. If toilet waste is also treated in biogas plant, slurry from biogas plant to be treated in a septic tank soak pit arrangement.

5. Clean the inlet chamber after each feed and keep it closed
6. Prohibited to feed wastes of slow degrading nature like straw, soil, egg shells, fibrous materials like banana leaves, coconut shells, coconut coir ,pseudo stem etc .Feeding of toxic substances like fungicides, insecticides, pesticides, detergents, and disinfectant like phenyl, dettol etc. are also prohibited.
7. Mix the substrate or rotate the drum at least weekly for preventing scum formation

Maintenance cost

Rs. 500/- annum per unit

2.3.2 Institutional level bio gas plant

2.3.2.a Institutional level (Floating Dome Type) biogas plant

Infrastructure & Specifications

1. Treatment Capacity - 50 to 200 kg of solid waste per day
2. Volume of digester;

Daily Waste Feed rate	50 Kg	75 kg	100 Kg	125 kg	150 kg	200 kg
Vol of digester	7.5 m ³	10 m ³	15 m ³	18 m ³	22 m ³	30 m ³

3. Volume of the gas holding dome;

Daily waste feed rate	50 kg	75 kg	100 kg	125 kg	150 kg	200 kg
Volume of gas holder	1.5 m ³	2.25 m ³	3 m ³	3.75 m ³	4.5 m ³	6 m ³

4. Digester with cement concrete/ Ferro cement with brick lining
5. Gas holder dome with Fiber Reinforced Plastic (FRP)
6. Central support of GI pipe of 50 to 65 mm (medium class), fixed to base concrete / fixed to central beam
7. Inlet device with PVC pipe of diameter 160 mm
8. Inlet chamber brick work with a lid of cement concrete with locking arrangements having circular shape of 60 cm diameter up to 100 kg/day plant and of 75 cm diameter for above 100 kg plants .
9. Outlet devise with PVC pipe of 140 mm diameter.
10. Water tank of capacity 100 litres upto 100 kg and 200 litres for plants above 100 kg capacity on brick staging.

11. Pre-filter tank with four chambers and waffle walls of capacity 2 M³ in between to pretreat the slurry output to reduce the load on the septic tank for plants 100 kg above
12. Septic Tank - Soak Pit system for treatment and disposal of effluent from biogas plants. Septic tank size 2 M³ of at least 2 compartments with maximum of 1.7 m depth and L: B: H ratio of 7.5: 2.25: 1. The soak pit have to be brick paved at bottom, honey-comb or perforated ring inside wall and filled up with brick jelly. Vent pipe is not necessary.

*Plant to be established in a place fully exposed to sunlight and away from drinking water source

Standards

1. Minimum waste retention time of 45 days
2. All PVC pipe of class 4 kg/cm²
3. Rubber hose, stove and control valve with ISI mark
4. Particle size of waste not to exceed 20 mm
5. Rubber hose of ¾ to 1 inch diameter with a maximum length of 40 m for conveyance of biogas
6. Minimum thickness of GI Sheet for gas holder of 2 mm
7. The capacity of the bio gas plant to be mentioned in terms of the loading rate (ie, maximum quantity of waste to be fed in kg per day)

Unit cost

Unit cost in Rs lakh is given ,capacity wise as under:-

50kg	75kg	100kg	125kg	150kg	200
1.2	1.50	1.75	1.90	2.00	2.25

O&M Protocols

1. Start up by adding cow dung and equal quantity of water.
2. Waste feeding after chopping and mixed with water in the ratio 1:1.
3. Daily feeding of easily degradable waste in slurry form or solid waste mixed with equal quantity of water.
4. Limit the quantity of daily waste feed below the designed capacity.
5. Maximum waste particle size of 20 mm.
6. Daily removal of slurry in to Septic Tank - Soak Pit system
7. Clean the inlet chamber after each feed and keep it closed.
8. Prohibited to feed wastes of slow degrading nature like straw, soil, egg shells, fibrous materials like banana leaves, coconut shells, coconut coir , pseudo stem etc .Feeding of toxic substances like fungicides, insecticides, pesticides, detergents, disinfectants like phenyl, dettol etc. are also prohibited.
9. Mix the substrate or rotate the drum at least weekly for preventing scum formation

Maintenance cost

1. Rs.20,000/- per unit as consultancy charge for technical support and capacity building for the initial period of six months .
2. Operation and maintenance cost per unit per annum capacity wise given in Re lakh. as under:-

50kg	75kg	100 kg	125 kg	150 kg	200 kg
0.20	0.25	0.30	0.33	0.35	0.40

2.3.2. b Institutional level (Fixed Dome Type) biogas plant

Infrastructure & Specifications

- 1 Treatment Capacity - 50 to 200 kg of solid waste per day
2. Volume of digester including gas holder;

Daily waste feed rate	50 kg	75 kg	100 kg	125 kg	150 kg	200 kg
Volume of digester	7.5 m ³	10 m ³	15 m ³	18 m ³	22 m ³	30 m ³

3. Digesters with cement concrete/ ferro-cement with brick masonry lining . .
4. Inlet device with PVC pipe of diameter 160 mm Inlet chamber with a lid of cement concrete having circular shape of 75 cm diameter with locking arrangements.
5. Balancing tank :

Balancing tank with Cement Concrete / Ferro cement	Waste feed rate (kg/day)	50	75	100	125	150	200
	Volume of digester (m ³)	7.5	10	15	18	22	30
	Total volume	1	1	1.2	1.2	1.5	1.5
	Liquid volume (m ³)	> 0.7	> 0.7	> 0.8	> 0.8	>1	>1

6. Outlet opening of 150 mm x 150mm size.
7. Outlet pocket and outlet tank with cement concrete/ brick masonry and the total liquid volume of 20 % of the digester volume.

8. Pre-filter tank capacity 2M3 with four chambers and waffle wall in between to treat the slurry output before sending to septic tank to reduce the load on the septic tank for plants of capacity 100kg and above .
9. Septic Tank - Soak Pit system for treatment and disposal of effluent from biogas plants. Septic tank of at least 2 compartments with maximum of 1.7 m depth and L: B: H ratio of 7.5: 2.25: 1. The soak pit have to be brick paved at bottom, honey-comb or perforated ring inside wall and filled up with brick jelly. Vent pipe is not necessary.

*Plant to be established in a place fully exposed to sunlight and away from drinking water source.

Standards

1. Minimum 45 days waste retention time
2. Particle size of waste not to exceed 20 mm
3. Rubber hose of $\frac{3}{4}$ to 1 inch diameter with maximum length of 40 m for conveyance of biogas
4. All PVC pipe of class 4 kg/cm²
5. Rubber hose, stove and control valve with ISI mark
6. The capacity of the bio gas plant to be mentioned in terms of the loading rate (ie, maximum quantity of waste to be fed in kg per day)

Unit cost

Unit cost capacity wise given in Rs lakh as under:-

50kg	75kg	100kg	125kg	150kg	200kg
1.0	1.25	2.00	2.20	2.50	3.00

O&M Protocols

1. Start up by adding cow dung and equal quantity of water.
2. Waste feeding after chopping and mixed with water in the ratio 1:1.
3. Daily feeding of easily degradable waste in slurry form or solid waste mixed with equal quantity of water.
4. Limit the quantity of daily waste feed below the designed capacity.
5. Maximum waste particle size of 20 mm.
6. Daily removal of slurry in to Septic Tank - Soak Pit system
7. Clean the inlet chamber after each feed and keep it closed.
8. Prohibited to feed wastes of slow degrading nature like straw, soil, egg shells, fibrous materials like banana leaves, coconut shells, coconut coir , pseudo stem etc .Feeding of toxic substances like fungicides, insecticides, pesticides, detergents, disinfectants like phenyl, dettol etc. are also prohibited.
9. Mix the substrate or rotate the drum at least weekly for preventing scum formation

Maintenance cost

1. Rs.20,000/- per unit as consultancy charge for technical support and capacity building for the initial period of six months .
2. Operation and maintenance cost per unit per annum in Re lakh is given as under:-

50kg	75kg	100kg	125kg	150kg	200kg
0.20	0.25	0.30	0.33	0.35	0.40

2.3.3 Community level bio gas plant

2.3.3.a Community level biogas plant (Floating Dome Type) (capacity 300 kg to 2000kg of solid waste per day.)

Infrastructure

1. Pre-processing room with space to accommodate the pulverizing /grinder mixer machine and an inlet mixing chamber for mixing the pulverized waste ,provision of a platform outside the room with extended roof and ramp , to receive the waste digester
2. Inlet mixing cum feeding tank near to the digester, with locking arrangements for feeding waste to the digester
3. Inlet devices with PVC pipe of diameter 150 mm, connecting the bottom of the inlet mixing chamber located inside the pre-processing room for conveyance of pulverized waste to the inlet feeding tank and connecting the inlet feeding tank and the digester
4. Digester with reinforced cement concrete and brick masonry lining on both sides and having the following;
 - a. Bottom slope of digester shall be 1 in 8 for easy withdrawal of sludge.
 - b. Outlet devise with PVC pipes 140 to 200 mm
 - c. Floating Gas holder dome with fibre reinforced plastic (FRP)
 - d. Central support of GI pipe medium grade 65 to 100 mm fixed to base concrete/ fixed to central beam of the dome.
5. Pumps of screw type or submersible type or external chemical process type for pumping water, slurry and sludge.
6. Pre-digester tank for increasing the efficiency of main digester/digesting of slow digesting items for plants of capacity 1 Ton and above.
7. A Pulverizing machine /grinder mixer for reducing the size of waste larger than 20mm and to mix the same with water and putting it into inlet mixing tank inside the pre-processing room. Waste to be converted into slurry form by mixing it with equal volume of water to feed in to the digester for easy and clog free digestion.
8. Pre-filter tank with four number of chambers in series with baffle walls in between. The slurry from the outlet manhole passes through the baffle walls and flow to the septic tank. Certain amount of slurry get settle down in the pre-filter which is to be cleared periodically. This is to reduce the load on the septic tank .
9. Septic tank - soak pit system for treatment and disposal of effluent from biogas plants.

10. Rubber hose for conveying gas 20 mm dia ,min 40 metres long,, moisture trap, H₂S scrubber, pressure blower ,fire arrestor, regulator and a gas stove to spend the gas.
11. Control Panel for monitoring / operation

Notes:-

- a. All metal parts to be coated with epoxy primer and epoxy enamel for avoiding corrosion.
- b. All masonry tanks to be coated with epoxy or other corrosion resistant coating.
- c. Plant to be established in a place fully exposed to sunlight and away from drinking water source.
- d. Gas utilisation for heating /cooking purpose.

Optional items(to be ordered separately)

- a. A balloon storage facility for storage of at least $\frac{3}{4}$ th of bio gas generated in a day. $\frac{1}{4}$ th quantity of the gas produced in a day is stored inside the floating gas holder chamber of the digester itself.
- b. Water heater working on bio-gas be mounted on the wall of the pre-processing room, with all safety arrangements and plumbing .Hot water be utilized to mix with the feed waste.
- c. Gas measuring meter for supplying the gas to the nearest domestic/commercial customer/s.
- d. Solar water heater for making hot water to mix with the water to maintain the temperature where considered necessary in plants of 1000kg to 2000 kg
- e. Bio gas engines of single mode fuel (using methane gas only) in special cases only after obtaining approval from Suchitwa Mission Additional facilities include;
 - i. Facility for utilizing the electricity generated for operating equipments in the plant / lighting the plant area.
 - ii. Facility for flaring of excess gas with automatic or semi automatic flame ignition.
 - iii. Facility for Biogas cleaning for removal of water vapour and H₂S concentration to 100 ppm or less

Standards

1. Minimum 45 days waste retention time
2. Particle size of waste not to exceed 20 mm
3. Rubber hose of $\frac{3}{4}$ to 1 1/2 inch diameter with maximum length of 40 m for conveyance of biogas
4. All PVC pipe of class 4 kg/cm²
5. Rubber hose, stove and control valve with ISI mark
6. The capacity of the bio gas plant to be mentioned in terms of the loading rate (ie, maximum quantity of waste to be fed in kg per day)

Specifications

1.Pre-processing room

- a. Foundation/basement: Random rubble masonry with cement mortar 1:6 foundation and basement, filled up with approved earth/ red soil, duly rammed in layers, concrete belt 5 cm thick PCC 1:4:8, over RR masonry, plinth height minimum 50cm above the ground level.
- b. Floor : Cement concrete 1:4:8 using 40 mm metal 75 mm thick and plastered with cement mortar 1:3, 12mm thick one coat and finished smooth by hand trowel
- c. Superstructure : Single brick wall 23 cm thick with cement mortar 1:6, plastered with 12 mm thick 1:4 cement plaster finished smooth with hand trowel on both sides. Steel windows on all four sides. Snowcem finish on external walls and dry distemper on internal walls. Windows to be painted with synthetic enamel paint two coats over a primer coat.
- d. Platform /doors: Platform outside the room at floor level, with extended roof to receive the waste. A ramp to move the trolleys up the platform. Door with opening 1.2 metre wide on the platform side to convey waste items larger than 20mm size for pulverizing. Another door 1 m wide for entry of operating staff. Steel doors duly painted with locking arrangements.
- e. Inlet mixing chamber : Inlet mixing chamber of suitable size to unload the /pulverized waste, constructed out of brick work duly plastered on both side on one corner of the room. The inlet devise of PVC/cement pipe to connect the bottom of the inlet tank to the inlet mixing cum feeding tank near to the digester wherein waste (not required to be pulverized) is directly mixed with water. This is the tank from where waste (both pulverized or otherwise) is fed to the digester.
- f. Roof :RCC slab 1:2:4, 10 cm thick, over which water tank and the gas balloon be placed. Provide steel rings three each on each side on the soffit of the slab projection outside for securing the gas balloon.
- g. Light /control panel : Lighting with CFL 15 W, suitable control panel with power points for Pulverizer/ slurry pump, etc

2. Inlet mixing cum feeding tank

Constructed out of brick masonry plastered with cement mortar 1 in 3 circular in shape with locking arrangements near to the digester. The inlet devise from the inlet mixing chamber feeds the pulverized waste into this tank and the normal waste which doesn't need any pulverizing is directly fed to this. This tank acts as the feeding tank to the digester.

3. Pre-Digester:

Pre-Digester tank to digest slow digesting waste at the rate 5% of the total waste for a period of 90 days for plants capacity 1 ton and above. Brick work duly plastered with 1:3 cement mortar finished fair with hand trowel.

4. Digester

Digester tank be designed with 40 days waste capacity duly mixed with equal amount of water.

a. Foundation /bottom

RCC 1:1/2 :3 , 15/20 cm thick over a layer of PCC 1:4:8 , 15cm thick over random rubble masonry with cement mortar 1:8 thickness 40 cm .Digester cylindrical shape and curved bottom with a slope of 1:8 ,for easy flow of slurry.

b. Side walls

RCC 1:1 ½ :3 thickness 15/20 mm, brick lining 10 cm ,on both the sides of the RCC wall. Walls to be plastered and finished with 12mm thick cement mortar 1:3. The side cylindrical shaped wall to anchor on the RR foundation on angle shoe shaped footing in case of plants of 800 kg and above. The structural details are given in the Sketch No 14

c. Floating dome

Made of fiber reinforced plastic moulding /epoxy coated MS of suitable diameter and a wedge shape edge all around at the bottom edge to float /slide up and down smoothly inside the digester. .It is cylindrical in shape body ,bottom side is open to the digester and top side is curved shaped and closed/ sealed ,the cavity formed inside to act as gas holder. Gas outlet pipe is connected to the top most point of the dome. The peripheral side of contact between the digester and the gas holder is provided with a water seal to prevent escape of gas . The floating dome is provided with a gas scrubber arrangements internally so as to keep stirring the slurry while moving up and down. The central GI pipe embedded into the concrete at the bottom of digester keeps the dome centrally in position

d. Outlet devise

The slurry gets pushed out through the PVC pipe 140/200 mm into a manhole chamber provided out side the digester from where the slurry gets pumped by a slurry pump into the pre-filter tank.

5. Pre-filter tank

Pre-filter brick construction plastered 12 mm thick 1:3 cement mortar with four chambers in series separated by RCC baffle walls .The slurry from the balancing tank to be pumped into the first chamber where it passes through the baffle walls and goes out through the outer chamber to the septic tank and then to the soak pit..Certain amount of slurry get settle down in the pre-filter which is to removed periodically. This reduces the load on the septic tank.

6. Septic tank and soak pit:-

Septic tank of 3 compartments with maximum of 1.7 m depth and L: B: H ratio of 7.5: 2.25: 1.2. The soak pit to be brick paved at the bottom, honey-comb or perforated ring inside wall .to be filled with brick jelly. Vent pipe is not necessary.

7. Water Tanks

PVC water tanks of required capacity be placed on the roof of the pre-processing room or on a separate staging on brick pillars in case the roof is fully occupied by the gas balloon.. Ground sump and monobloc pump as required.

8. Mechanical equipments

a. Pulverizer/grinder-mixer

A 3 hp 3 phase pulverizer 300 kg/hour rating for plants up to 1000 kg/day and 5 hp 400 kg/hour rating for higher capacity plants .Belt driven ,blades fixed on single shaft ,enclosed pulverizing chamber ,hopper loaded suitable for wet grinding.

b. Slurry pump

Slurry pump open impeller 1 hp for pumping the slurry out of outlet manhole into the pre-filter tank.

c. Biogas balloon

High tenacity polyamide fabric matrix impregnated with compatible polymer on the inside for the gas stored and on outside with hypalon weather abrasion and UV resistance . Balloon be placed above the roof of the pre-processing room and be secured by tying manila ropes around with the steel rings on the slab.

9. Notes:

- The sizes of various components of the bio-gas plants of different capacities are given in the Appendix E
- Layout and elevation of a typical plant is given in Sketch Nos 10 & 12.
- These specifications are given for normal strata of a mix of ordinary soil and hard soil in the ratio 50:50 .Care to be taken to modify the design according to the strata and the type of waste to be treated.

Land requirement

Land area 20mx10m for 300 kg plant to 30mx15m for 2000 kg plant

Unit cost

Total cost of setting up of a bio-gas plant capacity wise is given as under (in Rs lakhs):-

300 kg/d	400 kg/d	500 kg/d	600 kg/d	800 kg/d	1000 kg/d	1500 kg/d	2000 kg/d
4.97	5.52	5.91	6.29	6.8	7.94	9.88	11.3

Notes:

- The breakdown details of the costing has been given in Appendix F
- Estimating has been done based on Kerala PWD schedule rates 2010.
- Estimate is based “ all soil conditions “(mix of ordinary soil and hard soil in the ratio 50:50) and to be suitably modified for different site conditions
- Optional items are not included in the cost.
- The cost include contractors’ profit ,but doesn’t include statutory works tax or service tax

O&M Protocols

1. Start up by adding cow dung and equal quantity of water
2. Waste feeding after chopping and mixed with water in the ratio 1:1
3. Daily feeding of easily degradable waste in slurry form or waste mixed solid with equal quantity of water
4. Limit the quantity of daily waste feed below the designed capacity
5. Maximum particle size of waste shall be 20 mm
6. Daily removal of slurry in to Septic Tank - Soak Pit system
7. Clean the inlet chamber after each feeding and keep it closed
8. Prohibited to feed wastes of slow degrading nature like straw, soil, egg shells, fibrous materials like banana leaves, coconut shells, coconut coir , pseudo stem etc .Feeding of toxic substances like fungicides, insecticides, pesticides, detergents, and disinfectants like phenyl, dettol etc. are prohibited.
9. Mix the substrate or rotate the drum at least weekly for preventing scum formation
10. Skilled Manpower for Operation of the Plant.
11. Operation and maintenance contract with the executing agency/ supplier for a period of 2 years after installation and initial capacity building period of six months of plant

Maintenance cost

1. Consultancy charges in Rs for technical support and capacity building for the initial period of six months are as under:-

Upto 500kg plant	600-900kg plant	1000kg and above
30,000.00	40,000.00	50,000.00

2. Operation and maintenance cost per annum in Rs lakh capacity wise are given as under:-

300 kg	400 kg	500 kg	600 kg	800 kg	1000 kg	1500 kg	2000 kg
0.6	0.70	0.8	1.0	1.15	1.35	1.6	1.85

Note

The gas generated be utilised or sold to nearby customers by the local body.

2.3.3.b Community level (Fixed Dome Type) biogas plant capacity 300 to 2000 kg/day

Infrastructure

1. Pre-processing room with space to accommodate the pulverizing machine and an inlet mixing chamber to mix the pulverized waste. A platform outside with extended roof to receive the waste.
2. Inlet mixing cum feeding tank constructed near to the digester, with locking arrangements for feeding the waste to the digester.

3. Inlet devices with PVC pipe of diameter 150 mm one from the inlet mixing chamber for the pulverized waste located inside the pre-processing room to the common inlet mixing cum feeding tank located outside near the digester and another inlet pipe from this outside feeding tank to the digester.
4. Digester with reinforced cement concrete with brick masonry lining on both sides and having the following;
 - a. Bottom slope of digester shall be 1 in 8 for easy withdrawal of sludge.
 - b. Outlet opening with 200 to 300 mm diameter.
 - c. Outlet (balancing) tank with cement concrete/brick masonry lining on both sides having a free board of 30 cm
5. Pumps of screw type or submersible type or external chemical process type for pumping water, slurry and sludge.
6. Pre-digester tank for increasing the efficiency of main digester/digesting of slow digesting items in plants of capacity 1 ton and above
7. A Pulverizing machine /Shredder for reducing the size of items of bigger size into uniform size and mixing the same with water inside the mixing tank (No1)provided in the pre-processing room..
8. Pre-filter tank with four number of chambers in series with baffle walls in between to reduce the load on the septic tank .
9. Septic Tank - soak pit system for treatment and disposal of effluent from biogas plants.
10. Rubber hose for conveying gas 20 mm dia min 40 metres long, moisture trap, H₂S scrubber, pressure blower,fire arrestor, regulator and a gas stove to spend the gas.
11. Control panel for monitoring / operation

Notes:-

- a. All metal parts to be coated with epoxy primer and epoxy enamel for avoiding corrosion.
- b. All masonry tanks to be coated with epoxy or other corrosion resistant coating.
- c. Plant to be established in a place fully exposed to sunlight and away from drinking water source.
- d. Gas utilisation for heating /cooking purpose

Optional items(to be ordered separately)

- a. A balloon storage facility for storage of at least $\frac{3}{4}$ th of bio gas generated in a day.1/4 th quantity of the gas produced in a day is stored inside the gas holder chamber of the digester itself.
- b. Provide a water heater working on bio-gas with necessary safety arrangements and be mounted on the wall of the pre-processing room to heat the water before mixing with the waste input, along with necessary plumbing.
- c. Provision of gas measuring meter to supply gas to the nearest house-hold/commercial establishments on cost.
- d. Solar water heater for making hot water to mix with the water to maintain the temperature where considered necessary in plants of 1000 kg/day capacity and above.

- e. Bio gas engines of single mode fuel (using methane gas only).in special cases only after obtaining approval from Suchitwa Mission. Additional facilities include;
 - i. Facility for utilizing the electricity generated for operating equipments in the plant / lighting the plant area.
 - ii. Facility for flaring of excess gas with automatic or semi automatic flame ignition.
 - iii. Facility for Biogas cleaning for removal of water vapour and H₂S concentration to 100 ppm or less.

Standards

1. Minimum 45 days waste retention time
2. Particle size of waste not to exceed 20 mm
3. Rubber hose of ¾ to 1 1/2 inch diameter with maximum length of 40 m for conveyance of biogas
4. All PVC pipe of class 4 kg/cm²
5. Rubber hose, stove and control valve with ISI mark
6. The capacity of the bio gas plant to be mentioned in terms of the loading rate (ie, maximum quantity of waste to be fed in kg per day)

Specifications

1.Pre-processing room

- a. Foundation/basement : Random rouble masonry with cement mortar 1 in 6 , filled up with approved earth/ red soil, concrete belt 5 cm thick PCC 1:4:8, plinth height minimum 50cm above the ground level.
- b. Floor : Cement concrete 1:4:8 using 40 mm metal 75 mm thick and plastered with cement mortar 1:3 ,12mm thick one coat and finished smooth by hand trowel.
- c. Superstructure : Single brick wall 23 cm thick with cement mortar 1:6, plastered with 12 mm thick 1:4 cement plaster finished smooth with hand trowel on both sides. Steel windows on all four sides .Snowcem painting on the external walls and dry distemper on internal walls. Metal parts to be given synthetic enamel 2 coats over a primer coat.
- d. Platform /doors : A platform of adequate size outside the pre-processing room ,sides open, under the same roof with a ramp of size 2mx1m to unload the waste on arrival at the plant site. Door with opening of 1.2 metre wide on the platform side , another door 1 m wide for entry of operating staff.
- e. Inlet mixing chamber : Of suitable size to unload the mixed /pulverized waste, constructed out of brick work duly plastered on both side on one corner of the room. The inlet devise of PVC/cement pipe to connect bottom of the inlet tank to the inlet chamber located near to the digester.
- f. Roof : RCC slab 1:2:4 , 10 cm thick, over which water tank and the gas balloon be placed. Provide steel rings 3 each on the soffit of the slab projections outside the enclosed room for tying up the gas balloon with Manila ropes/belts.
- g. Light /control panel : Lighting with CFL 15 W ,suitable control panel with power points for pulverizer ,slurry pump etc.

2. Inlet mixing cum feeding tank

Constructed out of brick masonry plastered with cement mortar 1 in 3 circular in shape with locking arrangements near to the digester. The inlet device from the inlet mixing chamber feeds the pulverized waste into this tank and the normal waste which doesn't need any pulverizing is directly fed to this. This tank acts as the feeding tank to the digester.

3. Pre-Digester:

Pre-Digester tank to digest slow digesting waste at the rate 5% of the total waste for a period of 90 days. Brick work duly plastered with 1:3 cement mortar finished fair with hand trowel. This is to be provided in the plants of capacity more than 1 Ton per day.

4. Digester

Digester tank be designed with 40 days waste capacity duly mixed with equal amount of water.

- a. Foundation /bottom : RCC 1:1/2 :3 15cm thick for plants upto 600 kg/d plant and 20 cm thick for plant of capacity 800 KG and above over a layer of PCC 1:4:8, 15cm thick over random rubble masonry with cement mortar 1:8 thickness 40 cm. Digester cylindrical shape, bottom with a slope of 1:8, for easy flow of slurry. Top hemispherical shape to accommodate the gas generated. The gas holder to contain 25% of the gas generated in a day.
- b. Side walls and top : 15/ 20 cm RCC 1:1 ½ :3 wall, brick lining 10 cm, on both the sides. Roof slab RCC 15/20cm thick with brick lining 10cm thick inside. Walls to be plastered and finished with 12mm thick cement mortar 1:3. Reinforcement details are shown in Sketch No 14. The whole digester be constructed below the ground level.
- c. Outlet opening : 200/300 cm circular opening for the slurry to move into the outlet balancing tank.
- d. Outlet balancing tank : Out balancing tank of the same specification of the digester tank as explained above

5. Pre-filter

Pre-filter, brick construction plastered 12 mm thick 1:3 cement mortar, with four chambers in series separated by RCC baffle walls. The slurry from the balancing tank to be pumped into the first chamber where it passes through the baffle walls and comes out from the last chamber and flows into the septic tank. Certain amount of sludge get deposited in this pre-filter which is to be removed periodically. Provision of pre-filter reduces the load on the septic tank

6. Septic tank and soak pit:-

Septic tank of 3 compartments with maximum of 1.7 m depth and L: B: H ratio of 7.5: 2.25: 1.2. The soak pit bottom to be paved with bricks, sides honey-combed brick work inside filled up with brick jelly. Vent pipe is not necessary.

7. Water Tanks

PVC water tanks of required capacity be placed on the roof of the plant room. In case there is no space on the roof as gas balloon may occupy the full area a separate staging with brick pillars be constructed to place the water tank. Ground sump and monobloc pump as required.

8. Mechanical equipments

- a. Pulverizer : A 3 hp 3 phase pulverizer 300 kg/hour rating for plants up to 1000 kg/day and 5 hp 400 kg/hour rating for higher capacity plants .Cutting blades on single shaft, belt driven enclosed pulverizing chamber ,hopper loaded ,fixed with 3 phase motor, suitable for wet grinding.
- b. Slurry pump : Slurry pump open impeller type 1 hp for pumping the slurry out of outlet chamber into the pre-filter tank mounted on portable base with wheels and flexible hoses on the suction and delivery sides.
- c. Biogas balloon :High tenacity polyamide fabric matrix impregnated with compatible polymer on the inside for the gas stored and on outside with hypalon weather abrasion and UV resistance .Balloon be placed above the roof of the pre-processing room. This may be tied up with the roof by means of Manila rope and sleeves around.

9. Notes:

- a. The sizes of various components of the bio-gas plants of different capacities are given in the Appendix G
- b. Layout and elevation of a typical plant is given in the Sketch Nos.11 & 13
- c. These specifications are given for plants to be built up in normal strata with a mix of ordinary soil and hard soil in the ratio 50:50 . Care to be taken to modify the design to suite the site conditions

Land requirement

5 to 10% more land area than the floating drum type plant

Unit cost

Total costs of setting up of a bio-gas plant is given capacity wise as under(Rs lakh):-

300 Kg/d	400 Kg/d	500 Kg/d	600 Kg/d	800 Kg/d	1000 Kg/d	1500 Kg/d	2000 Kg/d
5.9	6.8	7.42	8.17	9.1	10.3	13.0	15.9

Notes:

- a. The detailed costing has been given in Appendix H
- b. Estimating has been done based on Kerala State PWD schedule of rates 2010.
- c. Estimate is based all “soil conditions “(50% ordinary soil and 50% hard soil) and to be suitably modified for different site conditions. Any changes in the design to be ratified by the competent authority.
- d. Optional items are not included in the cost.
- e. The estimate includes contractors’ profit of 10% but doesn’t include statutory works tax or service tax.

O&M Protocols

1. Start up by adding cow dung and equal quantity of water
2. Waste feeding after chopping and mixed with water in the ratio 1:1
3. Daily feeding of easily degradable waste in slurry form or solid waste mixed with equal quantity of water
4. Limit the quantity of daily waste feed below the designed capacity

5. Maximum particle size of waste shall be 20 mm
6. Daily removal of slurry in to Septic Tank - Soak Pit system
7. Clean the inlet chamber after each feeding and keep it Closed.
8. Prohibited to feed wastes of slow degrading nature like straw, soil, egg shells, fibrous materials like bananaleaves, coconut shells, coconut coir , pseudo stem etc . These be put into pre-digester for pre-digestion
9. Feeding of toxic substances like fungicides, insecticides,pesticides, detergents, and disinfectants like phenyl, ettol etc. are prohibited.
10. Mix the substrate or rotate the drum at least weekly for preventing scum formation.
11. Skilled Manpower for Operation of the Plant.
12. AMC with the executing agency/ supplier for a period of 2 years after installation and initial capacity building period of six months.of plant

Maintenance cost

1. Consultancy charges for technical support and capacity building for the initial six months given below in Re lakh ,capacity wise

Upto 500 kg plants	600-900 kg plants	1000 kg and above
0.30	0.40	0.50

2. Operation and maintenance cost per annum in Re lakh, after the initial six months period ,plant wise given as:-

300 kg	400 kg	500 kg	600 kg	800 kg	1000 kg	1500 kg	2000 kg
0.60	0.80	1.0	1.2	1.4	1.5	1.7	1.85

Note:

The gas generated will be utilised /sold to nearby customers by the local body.

3. SUBSIDY NORMS

- 3.1 Promotion of household level and institutional level facilities as decentralized solid waste treatment option is essential for reducing load in the centralized treatment facility. As a beginning subsidy shall be given as follows for household level vermi-compost facility, compost facility and biogas plant.
 - i) Household level vermi compost facility: 50 % of the capital cost for procuring vermi-compost kit subject to a maximum of Rs. 400 per unit. The subsidy is to be sanctioned to the kudumbashree unit/agency which supplies the vermi compost kit.
 - ii) Household level anaerobic compost facility : 50 % of the capital cost for installation of anaerobic compost units with concrete rings and cover slab, subject to a maximum of Rs. 900 per unit.
 - iii) Household level portable low cost biogas plants / pucca biogas plants: 50 % of the capital cost for installation of biogas plants subject to a maximum of Rs.3250 per unit.
- 3.2 The cost for setting up vermi compost/ composting / biogas plants at the institutional and community levels can be met by the Local Governments.

4. GENERAL CONDITIONS

- 4.1 Efficiency of electrical energy generation from biogas plants from solid waste is yet to be proven, hence it is better to utilize the biogas generated as such for cooking or heating purposes. Therefore, at this stage, projects on Waste to Energy Plants using biogas from Organic Fraction of solid waste shall not be promoted.
- 4.2 Facility for flaring of excess biogas gas should be provided in the community level biogas plants.
- 4.3 Skilled Manpower should be made available for operation of community level vermi-compost plants , windrow compost plants and. biogas plants.
- 4.4 The indicative unit cost given is the cost inclusive of installation of the facility and for performing trial run for a period of six months from the date of starting of trial run. This will include technical support and capacity building activities for the sustainable operation of all categories of plants.
- 4.5 Operation and Maintenance Contract (O & M) agreement shall be entered with the consultant / supplier of the treatment facility for a period of 3 years in the case of institutional and community level plants.
- 4.6 For procurement of vermi compost kit and the worms required for household, institutional and community level plants priority should be given to kudumbashree units.

5. PAYMENT CONDITIONS

5.1. Vermi Compost / Windrow Compost Shed

Payment will be made in the following stages;

- i. On completion of foundation and basement including filling of earth and provision of concrete belt over the RR masonry and after submission of detailed design drawings : 10% of the cost of the shed
- ii. On completion of columns and tie beams : 20% (total)
- iii. After the stage (i), as above and on completion of roofing : 50%(total).
- iv. On completion of the shed in all respect including flooring, vermi pits ,side wall, platform, store room etc except for the lighting(included in the electrification) : 75% (total)
- v. On completion of the trials : 90%
- vi. On completion of the O&M period : final bill

Other buildings

- i. Foundation and basement , including filling ;and concrete belt : 10%
- ii. Superstructure including roof slab : 50%
- iii. Completion : 75%
- iv. After trial period : 90%
- v. After O&M period : final bill

Electrification/water supply

- i. Against materials : Cost of materials as per voucher or 50% of the contract amount whichever is less
- ii. On completion : 90%
- iii. On completion of O & M final bill: They can claim 10% towards final bill against Bank Guarantee.

Equipments

- i. Against delivery : 75% of the cost /contract amount whichever is less
- ii. On completion of trials : 90%
- iii. On completion of six months' O&M period : final bill

5.2. Bio-gas plants

5.2.1. Buildings

As above

5.2.2. Digester

- i. Foundation and bottom side concrete: 10%
- ii. Side walls : 40%
- iii. Roof slab and balance items : 75%
- iv. Completion of trial : 90%
- v. After O&M period : final bill

5.2.3. Other items like pre-filter/ septic tank

on completion 75%

After trials : 90%

After O&M paid : final bill

5.2.4. Equipments/Electrical/Water supply

as per Vermi & Windrow

6. GUIDELINES ON MEMORANDUM OF UNDERSTANDING / O&M AGREEMENT FOR TREATMENT OF SOLID WASTE

6.1. Format for memorandum of agreement for establishment of a solid waste treatment plant

This memorandum of Agreement is made and executed at on this day of

BETWEEN M/s (Hereafter called the Agency) AND the Secretary (Hereafter called the Local Government)

- I. The expressions, Agency and the Local Government, wherever occur hereunder shall mean and include and always deem their successors, their representatives, assignees, executors, administrators and successors in Office etc.,
- II. Whereas, Agency has offered the services to undertake the work of Construction of plant for management of solid waste at after having thoroughly understood the obligations, terms and conditions involved in the job and after realizing all its implications, came forward and offered the services and placed the same at the disposal of the Local Government.
- III. The Agency has deposited a sum of Rs..... as security deposit with the Local Government, which will be refunded to the agency after commissioning and successful operation of the plant.

IV Terms & Conditions of the Memorandum of Agreement:

A. For establishment of the plant

- i. The agency shall build a plant as per specification attached
- ii. The agency shall bear all cost incurred for water, electricity, loading and unloading charges and any other cost likely to occur during the construction
- iii. The local government will pay the agency the rates approved as per tender no dated
- iv. The site shall be handed over to the agency within 7 days of signing the agreement. The title, ownership and rights with regard to the land will vest with the Local Government.

- v. The Agency should complete the construction work and install all machineries (where ever applicable) within 4 months from the date on which the site is physically handed over to the agency
- vi. The Agency should carry out the construction as per the calendar attached
- vii. The local body should get the consent of the KSPCB and other agencies as required under law.
- viii. The Agency should submit monthly progress report to the local government or any other person authorized by the local government
- ix. The plant should be commissioned on
- x. The plant shall have a trial run for a period of 6 months during the period the waste will be managed by the agency. The funds for the trial run shall be included in the tender
- xi. The agency shall ensure that the plant attains its full capacity during the trial period
- xii. The agency shall ensure that construction of the plant and erection of machineries (where ever required) is completed within a period of four months from the date of handing over physical possession of the site. The work shall have to be completed to the satisfaction of the Local Government.
- xiii. Suitable extension can be granted by the Local Government provided it is satisfied that the delay was unavoidable. In case failure on the part of the agency to complete the work within the stipulated period is adjudged by the Local Government to be attributable to causes within the control of the agency, then the agency shall pay to the Local Government compensation at the rate of 0.005% per week of the total estimated cost of the tender (as assessed by Local Government) subject to a maximum of 2.0 % of the total estimated cost of the concerned public convenience. The Local Government may levy and collect compensation at a rate lower than 0.005% depending upon its assessment of the circumstances of delay. The decision of the Local Government in this regard shall be final and binding upon the agency. Action under this clause of this agreement shall be without prejudice to any other right or remedy available under law to the Local Government.
- xiv. The agency or supplier shall give warranty for all equipment supplied for a period of 2 years. The warranty shall cover all service and replacement cost.
- xv. The local Government shall provide segregated biodegradable waste between andKilograms daily during the trial period. The biodegradable component of the waste supplied shall be 90% + 10%

- xvi. After completion of each facility, the agency shall provide 3 sets of completion plans including plans of various services provided therein including electrical drawing, water supply, sewerage, drainage drawings etc., along with inventory of various fitting & fixtures. Details of all equipments and diagrams (where ever necessary) shall be provided by the agency to the Local Government
- xvii. On the completion of the contract period, the agency shall hand over the land, building, equipments along with fixtures and fittings and inventory.
- xviii. That any of the conditions mentioned in this agreement can be altered modified, changed or removed by the appropriate authority as per the necessity without assigning any reason.

In witness there of Agency and the Secretary, Local Government, here into set their hands on this day of at

Signature of the agency

(Affix rubber stamp)

Witness:

- 1.
- 2.

Signature of the Secretary LOCAL GOVERNMENT.

Witness:

- 1
- 1.

PS. This is a supplementary agreement to be signed along with the agreement as per PWD Manual. In case of any contradiction with the PWD agreement the conditions of agreement as per PWD manual will prevail.

6.2. Format for memorandum of agreement for operation & maintenance of solid waste treatment plant

This memorandum of Agreement is made and executed at on this day of

BETWEEN M/s (Hereafter called the Agency) AND the Secretary (Hereafter called the Local Government)

- I. The expressions, Agency and the Local Government, wherever occur hereunder shall mean and include and always deem their successors, their representatives, assignees, executors, administrators and successors in Office etc.,
- II. Whereas, Agency has offered the services to undertake the operation and maintenance of plant for management of solid waste at after having thoroughly understood the obligations, terms and conditions involved in the job and after realizing all its implications, came forward and offered the services and placed the same at the disposal of the Local Government.
- III. The Agency has deposited a sum of Rs..... as security deposit with the Local Government, which will be refunded to the agency at the end of the contract period.
- IV. Terms & Conditions of the Memorandum of Agreement;

A. Operation & Maintenance

- i. The agency shall operate and maintain the plant for a period of years starting from till
- ii. The agency will keep the plant and its surroundings clean, hygienic, odourless and dust free to the complete satisfaction of Local Government.
- iii. The charges towards electricity, water, sewage and other such amenities shall be paid by the agency.
- iv. The Local Government shall not charge any license fee for the land and equipments provided to the agency.
- v. The agency shall ensure that the premises are not used for any un-lawful activities.

- vi. The entire structure as constructed along with fittings and fixtures provided in the plant will be handed over to the Local Government, on the conclusion of the agreement without causing any damage.
- vii. In case of loss due to theft or damage to the assets created in the plant, the agency shall be responsible for making good the same immediately at its own cost and shall continue to keep the plant operational.
- viii. In case of stoppage of works at any stage due to circumstances beyond the control of the agency, each instance will be reviewed and decision will be taken on a case by case basis.
- ix. Both the parties shall be at liberty to cancel this agreement at any stage after giving three months notice from either side if they find the arrangement not workable according to their aims and objectives.
- x. In the event of the Local Government considering it unavoidably and absolutely necessary in the interest of public necessity / requirement to take over the site and plant it shall do so after giving a minimum of three months advance notice.
- xi. In such circumstances as in clause (ix) and (x) The agency will continue to operate the plant till it is taken over by the Local government.
- xii. Disputes if any arising during the period of this agreement between Local Government and the agency shall be referred to the sole arbitration of the Commissioner, Local Government or a person nominated by him (the fact that the person so nominated is also and employee of Local Government shall not be a bar on his acting as an Arbitrator, nor shall any of the parties have any objection to his nomination for the said reason). The decision of the Sole Arbitrator so appointed shall be final and binding on both the parties. The venue of Arbitration shall be at the head quarters of the local government. The courts in head quarters of the local government shall have exclusive jurisdiction, to the exclusion of all other suits.
- xiii. The Local Government shall have the right to cancel / remove / terminate the agreement at any stage in case of breach of any of the stipulated terms and condition by the agency or in case their performance is not found satisfactory.
- xiv. The Local Government shall be entitled to terminate the agreement in case of any neglect or lapse on the part of the agency in respect of the regular maintenance of the facility in clean and hygienic conditions.
- xv. The agency shall keep the plant and all equipments in a state of good working condition at its own cost.

- xvi. The site and the work assigned to the agency by the Local Government shall not be transferred by the agency to any person, trust, society or institution in any manner whatsoever at any time whether during or after the termination of this agreement.
- xvii. The premises of plant shall not be used by the agency for purpose other than that for which it is allowed under the agreement for operation and maintenance.
- xviii. The agency or its employees or agents shall behave and deal with courtesy.
- xix. The agency will not use or allow any person to use plant or its premises for residential purpose and not keep any animal / motor vehicle in or around the complex other than those permitted by mutual consent.
- xx. The agency shall be allowed to plant flowering and other shrubs around the plant subject to the approval by the Local Government.
- xxi. The agency shall ensure enforcement of existing labour laws. Minimum Wages Act and at no point of time, the Local Government shall be drawn into litigations on these counts.
- xxii. The agency shall ensure that services of water supply, sewerage, drainage, electricity, telephone etc., in this vicinity encountered during the period of running / maintenance are not damaged. In case these are required to be shifted, the same shall be done by the department.
- xxiii. On the completion of the contract period, the agency shall hand over the possession of the site and plant along with fixtures and fittings, inventory, structures in good working condition to the Local Government within 24 hours and will not put any resistance failing which the premises shall be evicted and the Local Government shall assume the occupation without any notice whereupon the agency will have no claim.
- xxiv. The running cost of the plant will have to be met by the Agency and the Local Government will pay the agency an amount of Rs per tonne of waste received and processed in the plant
- xxv. The agency shall have the right to sell the fertilizer produced in the factory and the sales proceeds will be the right of the agency.
- xxvi. In case gas is produced by the plant the agency shall have the right to sell the gas so produced and the sales proceeds will be the right of the agency.
- xxvii. The agency shall carry out Annual preventive maintenance on the building and equipments so as to ensure their full utility over a period of time.

- xxviii. The local government or its representative will have the power for inspecting with plant as and when required and the agency shall in no way prevent the local government inspection
- xxix. Standard operating procedures should be prepared and followed for the working of the plant
- xxx. The local Government shall provide segregated biodegradable waste between andKilograms daily. The biodegradable component of the waste supplied shall be 90% + 10%
- xxxi. That Agency is willing to abide by all the above stipulated terms and conditions as laid down in the agreement.
- xxxii. That any of the conditions mentioned in this agreement can be altered, modified, changed or removed by the appropriate authority as per the necessity without assigning any reason and the new conditions shall be binding on the part of the first part.

In witness there of Agency and the Secretary, Local Government, here into set their hands on this day of, at

Signature of the agency

Witness

- 1. **(Affix rubber stamp)**
- 2.

Signature of the Secretary LOCAL GOVERNMENT.

Witness:

- 1.
- 2.

INFRASTRUCTURE REQUIREMENTS OF VERMI COMPOST PLANTS**(CAPACITY 250 kg/ day to 2000 kg/day)****1. Vermicompost shed**

Sl No	Capacity (Kg/day)	Reception Platform (mxm)	Shredding area (mxm)	Windrows Area (mxm)	Vermi tanks size (mxmxm) &nos	Leachate collection tank (mxmxm)	Store (m x m)	Shed Size (mxm)
1.	250	2 x 2	2x2	2.8x4.3	1.56x1x0.50 12 Nos	1 x 1 x0.5	3x5	10x15
2.	500	2 x 2	2x2	6x4.3	1.25x1x0.50 28 Nos	1.25x1.25x0.5	5 x 5	14x15
3.	1000	4 x 2	4x2	12x4.3	2.25x1x0.5 28 Nos	1.5x1.5x0.5	6.5x5	24x15
4.	2000	6 x 2	6x2	20x4.3	4.5 x 1x0.5 28 Nos	2x2x0.50	12x5	42x15

INFRASTRUCTURE REQUIREMENTS OF VERMI COMPOST PLANT (Contd)

2. Miscellaneous items

Capacity kg per day	Office and Rest room Wash area (sq.m)	Guard Room (sq.m)	Cow-dung/Nursery Shed (sq.m)	Cow dung Tank (mxmxm)	Nursery Tank (mxmxm)	Land Requirement (sq.m)
250	16	-	12	1x1x1	1x1x1	1200
500	16	-	12	1x1x1	1x1x1	1500
1000	42	6.2	15	2x1x1	1x1x1	1800
2000	42	6.2	15	2x1x1	1x1x1	2600

Note: Dimensions are as per typical lay out and can vary with in the over all area.

ESTIMATED COST OF VERMI COMPOST PLANT —CAPACITY 250 Kg/day to 2000 Kg/day**APPENDIX-B**

Sl No	Item	250 kg/d	500 kg/d	1000 kg/d	2000 kg/d
1	Compost shed	7,15,000.00	9,95,000.00	16,95,000.00	29,54,000.00
2	office restroom, wash area	1,41,600.00	1,41,600.00	3,97,000.00	3,97,000.00
3	cow-dung/nursery shed	49,000.00	49,000.00	61,250.00	61,250.00
4	Guard room	-	-	83,400.00	83,400.00
5	Electrification	70,000.00	90,000.00	1,10,000.00	1,40,000.00
6	Water supply	35,000.00	40,000.00	50,000.00	60,000.00
7	Green belt	20,000.00	25,000.00	35,000.00	45,000.00
8	Septic tank soak pit	17,000.00	17,000.00	17,000.00	17,000.00
8	Gate	10,000.00	10,000.00	10,000.00	10,000.00
9	Equipments	80,000.00	86,400.00	1,38,200.00	1,57,400.00
10	TOTAL	11,37,600	14,54,000.00	25,96,850.00	39,25,050.00
	say	11.4	14.6	26.0	39.3

Notes:-

1. Cost of boundary wall with random rubble masonry foundation and concrete block Wall 6' high be taken as Rs 1500/ per RM.
2. Cost of road be taken as Rs 1780/per 10 sq.m carpet area-for 2 layers of 100mm thick metalling and 20mm thick carpeting.

**APPENDIX-C-
INFRASTRUCTURE REQUIREMENTS OF WINDROW PLANTS 1 TO 5**

TONS/DAY

A.COMPOST SHED

Sl. No	Capacity Tons/day	Receipt Platform (mxm)	Windrows Space (mxm) Widthxlength & nos	Shredding area (mxm)	Maturity Sieve & Packing area(mxm)	Store Size (mxm)	Compost ShedArea (mxm)	Land Area mxm
1.	1	2x3	2x1.35 13 Nos	2 x 2	3 x 8	3 x 7	15x 11.5	35x42
2.	2	4x3	2 x 1.35 26 Nos	2 x 2	5 x 8	5 x 7	15x 18	35x48
3.	3	6 x 3	2 x 2 26 Nos	2 x 2	7 x 8	7 x 7	15x 24	35x54
4.	4	8 x 3	2 x2.7 26 Nos	2x 2	9 x 8	9 x 7	15x 32	35x62
5.	5	10x 3	2 x 3.65 26 Nos	2 x 2	11 x 8	11 x 7	15x 38	35x68

B.MISCELLANIOUS ITEMS

Capacity Ton/day	Anaerobic bays size (mxm) & Nos	Cow-dung store size (mxmxm)	Non-biodegradable store (mxmxm)	Shed for aneorobic Cowdung & non-bio-degradables (mxm)	Water tank capacity litres	Office cum Rest room & Wash area (sq. m)	Guard room (sq.m)
1	2x1x1 6 Nos	2 x 2.6x2.4	2x2.6x2.5	6 x 14	1000	16.5	-
2	2 x 1 x1.25 12 Nos	2 x2.6x2.4	2x2.6x2.4	6 x 18	1000	16.5	-
3	2 x1 x1.5 12 Nos	2x2.6x2.4	2x2.6x2.4	6 x 18	2000	42	6.5
4	2.5x1.25x1.5 12 Nos	2.5x2.6x2.1	2.5x2.6x2.1	6x22	2000	42	6.5
5	2.5x1.5x1.5 12 Nos	2.5x2.6x2.4	2.5x2.6x2.4	6 x 22	3000	42	6.5

INFRASTRUCTURE FACILITIES FOR WINDROW PLANTS CAPACITIES TO 10 TONS/DAY

A. COMPOST SHED

SI No	Capacity (Ton/day)	Receipt Platform (mxm)	Space for receipt conveyor (mxm)	Shedder Area (m x m)	Windrows Space(widthx length) (mxm) & nos	Maturity bay (mxm)	Compost Shed Size (mxm)	Land area (m x m)
1.	6	3 x 3	2 x 5	2x 2	4 x 2 26 nos	6.5 x 14	15 x 41	35 x 72
2.	7	3 x 3	2 x 5	2 x2	4.67 x 2 26 nos	6.5 x 16	15 x 47	35 x 77
3.	8	3 x 4	2 x 5	2 x 2	5.34 x 2 26 Nos	6.5x 18	15 x 52	35 x 82
4.	9	3 x 5	2 x 5	2 x 2	6 x 2 26 Nos	6.5 x 20	15 x 57	35 x 87
5.	10	3 x 6	2 x 5	2 x 2	6.67 x 2 26 Nos	6.5 x 22	15 x 63	36 x 95

B. MISCELLANIOUS ITEMS

Capacity Ton/day	Storage Shed mxm	Anaerobic bays size (mxmxm) & nos	Cow dung store (mxmxm)	Non-biodegrad-bles store (mxmxm)	Shed for Anaerobic Cowdung & non biostore (mxm)	Water tank capacity (litres)	Office rest room & wash (sq. m)	Guard room (Sq.m)
6	12 x 7	3 x1.5x1.5 12 Nos	3 x 2.6x2.4	3x2.6x2.4	6x26	3000	52	6.5
7	14x 7	3 x 1.5x1.5 12 Nos	3 x2.6x2.4	3x2.6x2.4	6x26	4000	52	6.5
8	16x 7	3.5x1.5x1.5 12 Nos	3.5x2.6x2.4	3.5x2.6x2.4	6x30	4000	52	6.5
9	18x 7	3.5 x1.5x2 12 Nos	3 .5x 2.6x 2.4	3.5x2.6x2.4	6x30	5000	52	6.5
10	20x 7	4x1.5x2 12 Nos	4 x2.6x2.4	4x2.6x2.4	6x34	5000	52	6.5

Note:- Dimensions are based on model lay out and can vary with in the over all area

ESTIMATED COST OF WINDROW COMPOST PLANT- (CAPACITY 1 TON/DAY TO 5 TONS/DAY) - APPENDIX-D

<u>Sl.No</u>	<u>Item</u>	<u>1 Ton/day</u>	<u>2 Tons/day</u>	<u>3 Tons/day</u>	<u>4 Tons/day</u>	<u>5 Tons/day</u>
1	Compost shed	8,47,400.00	12,80,600.00	17,50,000.00	22,76,640.00	27,03,510.00
2	Office cum rest room washarea	1,41,600.00	1,41,600.00	3,97,000.00	3,97,000.00	3,97,000.00
3	Anaerobic & cow dung Shed & tanks	2,59,900.00	3,34,180.00	3,34,180.00	4,08,400.00	4,08,400.00
4	Guard room	-	-	83,400.00	83,400.00	83,400.00
5	Equipments	57,000.00	57,000.00	95,000.00	95,000.00	95,000.00
6	Electrification	90,000.00	1,00,000.00	1,15,000.00	1,20,000.00	1,25,000.00
7	Water supply	35,000.00	35,000.00	40,000.00	50,000.00	60,000.00
8	Green belt	32,000.00	35,000.00	43,000.00	45,000.00	50,000.00
9	Gate	10,000.00	10,000.00	10,000.00	10,000.00	10,000.00
10	Septic tank Soak pit	17,000.00	20,000.00	25,000.00	30,000.00	35,000.00
	TOTAL	1489900	2018380	2902600	3525440	3967310

ESTIMATED COST OF WINDROW COMPOST PLANT - (6 TONS/DAY TO 10 TONS/DAY) -APPENDIX -D (Contd)

<u>Sl.No</u>	<u>Item</u>	<u>6 Tons/day</u>	<u>7 Tons/day</u>	<u>8 Tons/day</u>	<u>9 Tons/day</u>	<u>10 Tons/day</u>
1	Compost shed	29,16,940.00	33,43,815.00	36,99,500.00	4055265.00	44,82,135.00
2	Office cum rest room washarea	5,00,000.00	5,00,000.00	5,00,000.00	5,00,000.00	5,00,000.00
3.	Store shed	3,48,000.00	4,06,000.00	4,64,000.00	5,22,000.00	5,80,000.00
3	Anaerobic & cow dung Shed & tanks	4,82,664.00	4,82,664.00	5,56,920.00	5.56,920.00	6,31,176.00
4	Guard room	83,400.00	83,400.00	83,400.00	83,400.00	83,400.00
5	Equipments	3,82,000.00	3,82,000.00	3,82,000.00	3,82,,000.0	3,82,,000.00
6	Electrification	1,50,000.00	1,60,000.00	1,70,000.00	1,80,000.0	2,00,000.00
7	Water supply	60,000.00	65,000.00	68000.00	70,000.00	75,000.00
8	Green belt	52,000.00	55,000.00	58,000.00	60,000.00	65,000.00
9	Gate	10,000.00	10,000.00	10,000.00	10,000.00	10,000.00
10	Septic tank Soak pit	40,000.00	45,000.00	50,000.00	55,000.00	60,000.00
12.	Total	5025000.00	55,32,875.00	6041820.00	64,74,585.00	7068711.00

INFRASTRUCTURE REQUIREMENTS OF A BIO-GAS PLANT-FLOATING DOME TYPE - (300 to 2000 kg per day)

Sl no	Capacity (Kg/day)	Digestr (m ³)	Gas holder (m ³)	Plant room (mxm)	Receipt Platform (mxm)	Inlet Mixing Chambr (mxmxm)	Mixing cum feeding tank DiaxD(mxm)	Pre-Digest-or (m ³)	Pre-filter (mxmxm)	Septic Tank (m ³)	Soak pit (diax Depth)-mxm	Water Tank (litres)	Gas balloon (m ³) (optional)	Gas- water Heater capacity Litres (optional)
1.	300	35	7.5	5x3	2x2	0.5x0.5x0.5	0.6x0.6	-	3x1x1	2.4	1.5X1.2	750	13.5	25
2	400	45	10	5x3	2x3	0.5x0.5x0.5	0.6x0.6	-	3x1.1x1	2.4	1.5X1.2	1000	18	25
3	500	57	12	5x3	2x3	0.5x0.5x0.5	0.6x0.6	-	3x1.5x1	3.0	1.5X1.5	1000	22.5	25
4	600	68	15	5x3	2x3	0.5x0.5x0.5	0.6x0.6	-	3x1.6x1	3.0	1.5x1.5	1250	27	25
5	800	90	19	5x3	2x3	0.6x0.6x0.6	0.6x0.6	-	3x1.8x1	4	1.6x1.5	1750	36	25
6	1000	115	24	5x4	2x4	0.6x0.6x0.6	0.75x0.6	5	3x2x1	5	2x1.5	2000	45	50
7	1500	170	36	5x4	2x4	0.6x0.6x0.6	0.75x0.6	6	4x2x1	6	2.5x1.5	3000	67.5	50
8	2000	225	48	5x4	2x4	0.6x0.6x0.6	0.75x0.6	9	5x2x1	8	3x1.5	4000	90	100

ESTIMATED COST OF A BIO-GAS PLANT—FLOATING DOME TYPE

APPENDIX-F

Sl.no	item	300 kg/day	400 kg/day	500 kg/day	600 kg/day	800 kg/day	1000 kg/day	1500 kg/day	2000 kg/day
1	Digester Incl.gas holder &balancing tank	2,02,000.00	2,38,500.00	2,85,000.00	3,19,600.00	3,60,000.00	3,87,,000.00	5,61,000.00	6,75,000.00
2	Plant room Incl platform & mixing tanks	1,27,000.00	1,27,000.00	1,27,000.00	1,27,000.00	1,27,000.00	1,75,000.00	1,75,000.00	1,75,000.00
3	Pre-digester	-	-	-	-	-	22,000.00	25,000.00	33,000.00
4	Pre-filter	20,500.00	22,000.00	23,500.00	25,000.00	26,500.00	27,500.00	32,000.00	35,000.00
5	Septic tank & soak pit	24,000.00	27,000.00	30,000.00	32,000.00	36,000.00	40,000.00	46,000.00	52,000.00
6	Water supply	12,000.00	14,000.00	14,000.00	14,000.00	14,000.00	14,000.00	16,000.00	20,000.00
7	Electrification	20,000.00	20,000.00	20,000.00	20,000.00	20,000.00	22,000.00	22,000.00	22,000.00
8	Gas pipe,scrubber Stove etc	15,000.00	15,000.00	15,000.00	15,000.00	20,000.00	20,000.00	25,000.00	30,000
9	Mech.equipments Pulverizer Slurry pump Trolley,chopper,etc	76,000.00	76,000.00	76,000.00	76,000.00	76000.00	86,000.00	86,000.00	86,000.00
10	Total	4,96,500.00	5,51,500.00	6,90,500.00	6,28,600.00	6,79,500	7,93,500	9,88,000.00	11,28,000.00

APPENDIX-G

INFRASTRUCTURE REQUIREMENTS OF A BIO-GAS PLANT-FIXED DOME TYPE (300 to 2000 kg per day)

Sl no	Capacity (Kg/day)	Digestor Incl.gas holder (m ³)	Plant room (mxm)	Receipt Platform (mxm)	Inlet Mixing Chambr (mxmxm)	Mixing Cum feedingtank DiaxD (mxm)	Balancing Tank (m ³)	Pre-Digest-or (m ³)	Pre-filter (mxmxm)	Septic Tank (m ³)	Soak pit (dixax Depth)-mxm	Water Tank (litres)	Gas balloon (m ³) (optional)	Gas water Heater Capacity (Litre (optional)
1.	300	41	5x3	2x2	0.5x0.5x0.5	0.6x0.5	4.5	-	3x1x1	2.4	1.5X1.2	750	13.5	25 litre
2	400	55	5x3	2x2	0.5x0.5x0.5	0.6x0.5	6	-	3x1.1x1	2.4	1.5X1.2	1000	18	25litre
3	500	68	5x3	2x3	0.5x0.5x0.5	0.6x0.5	8.5	-	3x1.5x1	3.0	1.5X1.5	1000	22.5	25 litre
4	600	82	5x3	2x3	0.5x0.5x0.5	0.6x.5	12	-	3x1.6x1	3.0	1.5x1.5	1250	27	25 litre
5	800	109	5x3	2x3	0.6x.6x.6	0.6x0.6	19	-	3x1.8x1	4	1.6x1.5	1750	36	25 litre
6	1000	137	5x4	2x4	0.6x.6x0.6	0.75x0.6	23	5	3x2x1	5	2x1.5	2000	45	50 litre
7	1500	205	5x4	2x4	0.6x0.6x0.6	0.75x0.6	30	6	4x2x1	6	2.5x1.5	3000	67.5	50 litre
8	2000	275	5x4	2x4	0.6x0.6x0.6	0.75x0.6	40	9	5x2x1	8	3x1.5	4000	90	100 litre

ESTIMATED COST OF A BIO-GAS PLANT—FIXED DOME TYPE**APPENDIX -H**

Sl. no	item	300 kg/day	400 kg/day	500 kg/day	600 kg/day	800 kg/day	1000 kg/day	1500 kg/day	2000 kg/day
1	Digester Incl.gas holder &balancing tank	2,95,000.00	3,77,250.00	4,36,050.00	5,07,600.00	5,88,800.00	6,22,000.00	8,69,500.00	11,34,000.00
2	Pre-proc- room Incl platform & mixing tanks	1,27,000.00	1,27,000.00	1,27,000.00	1,27,000.00	1,27,000.00	1,75,000.00	1,75,000.00	1,75,000.00
3	Pre-digester	nil	nil	nil	nil	nil	22000.00	25000.00	33000.00
4	Pre-filter	20,500.00	22,000.00	23,500.00	25,000.00	26,500.00	27,500.00	32,000.00	35,000.00
5	Septic tank & soak pit	24,000.00	27,000.00	30,000.00	32,000.00	36,000.00	40,000.00	46,000.00	52,000.00
6	Water supply	12,000.00	14,000.00	14,000.00	14,000.00	14,000.00	14,000.00	16,000.00	20,000.00
7	Electrification	20,000.00	20,000.00	20,000.00	20,000.00	20,000.00	22,000.00	22,000.00	22,000.00
8	Gas pipe& gas scrubber , pipe Stove etc	15,000.00	15,000.00	15,000.00	15,000.00	20,000.00	20,000.00	25,000.00	30,000.00
9	Mech.equipments Pulverizer Slurry pump Trolley,chopper,etc	76,000.00	76,000.00	76,000.00	72,000.00	76,000.00	86,000.00	86,000.00	86,000.00
10	Total	5,90,000.00	6,78,250.00	7,41,550.00	8,16,600.00	9,08,300.00	10,28,500.00	12,96,500	15,87,000.00

Notes:

1. Deenabandhu model Bio-gas plant may be provided upto 600 kg plant and in that case cost of Digester be reduced by 10%.
2. The cost as above includes contractor's profit of 10% ,but doesnot include the statutory work tax or service tax .

STRUCTURAL SPECIFICATIONS : FIXED DOME

ITEM	UPTO 600 KG/DAY	800 KG / DAY & ABOVE
Foundation	RR masonry 40 cm thick PCC 1:4:8, 40 mm metal 15 cm thick RCC 1:1.5:3, 20 mm metal 15 cm thick	RR masonry 40 cm thick PCC 1:4:8, 40 mm metal 15 cm thick RCC 1:1.5:3, 20 mm metal 20 cm thick
Wall	Inner & outer wall 10 cm thick, RCC vertical 1:1.5:3, 20 mm metal, 15 cm thick	Inner & outer wall 10 cm thick, RCC vertical 1:1.5:3, 20 mm metal, 20 cm thick
Bottom portion of outlet tank	RCC 1:1.5:3, 15 cm thick, PCC 10 cm thick, RR 40 cm thick	RCC 1:1.5:3, 15 cm thick, PCC 10 cm thick, RR 40 cm thick
Dome portion	One layer 10 cm brick work & RCC 1:1.5:3 15 cm thick	One layer 10 cm brick work & RCC 1:1.5:3, 20 cm thick
Plastering	Dome 1:1:2 (cement, coarse sand, fine sand) 12 mm thick	Dome 1:1:2 (cement, coarse sand, fine sand) 12 mm thick
Inner side	1:1:2 (cement + coarse sand + fine sand) 10 mm thick	1:1:2 (cement + coarse sand + fine sand) 10 mm thick
Outer side	As inner side	As inner side
Painting	Dome - Two coat black paint in inner side only	Dome - Two coat black paint in inner side only
Reinforcement details	1. Dome Bottom & top - 8 mm dia, 15 cm c/c 2. Vertical wall - 8 mm dia, 15 cm c/c, 8 mm dia, 20 cm c/c	1. Dome Bottom & top - 12 mm dia, 15 cm c/c double layer 2. Vertical wall - 12 mm dia, 15 cm c/c, double layer 12 mm dia, 20 cm c/c double layer

Note : Similar details to be followed for floating type, ⁵⁷except for the dome.

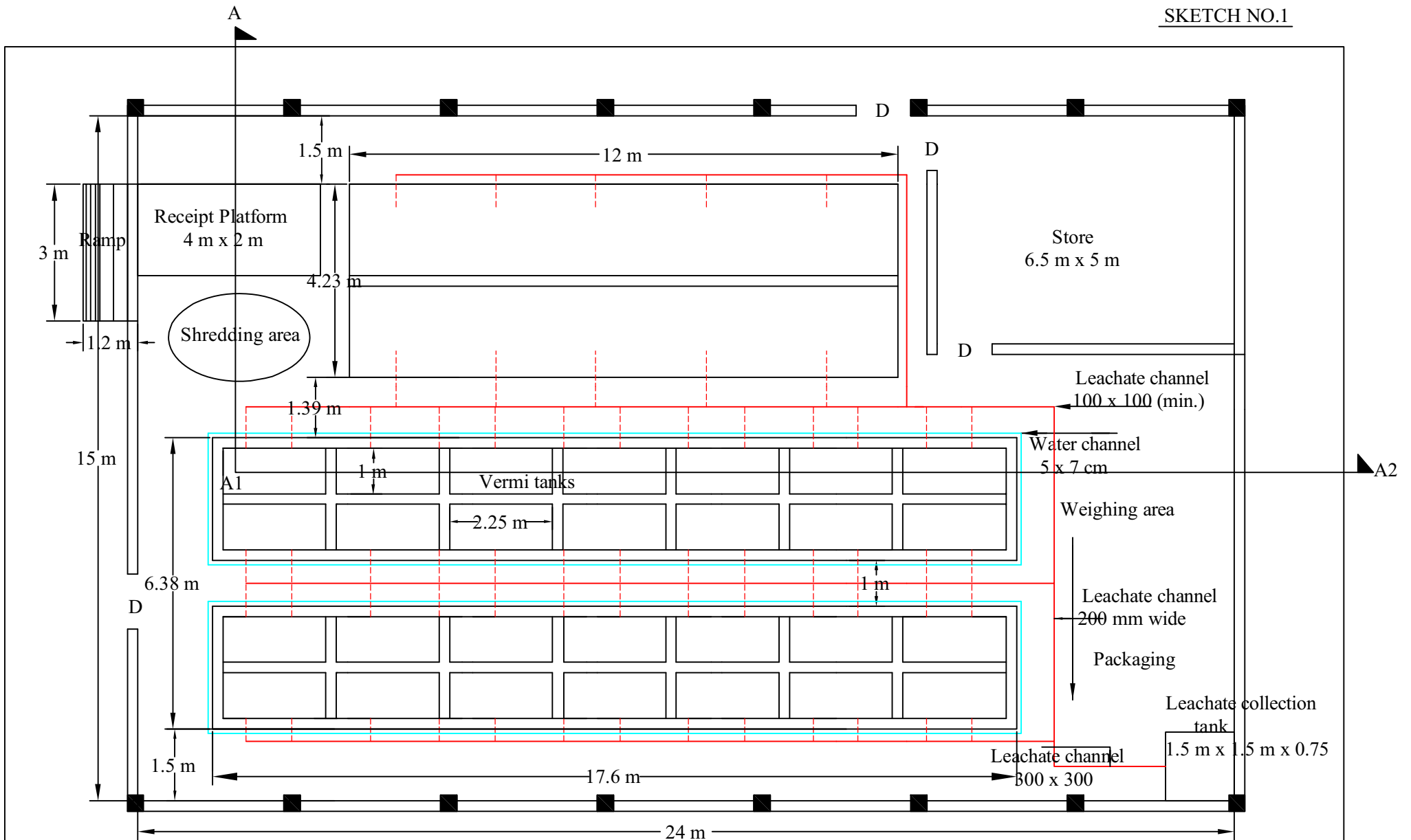

LAYOUT OF A TYPICAL VERMI COMPOST PLANT -
1 TONNE PER DAY CAPACITY

NOT TO SCALE

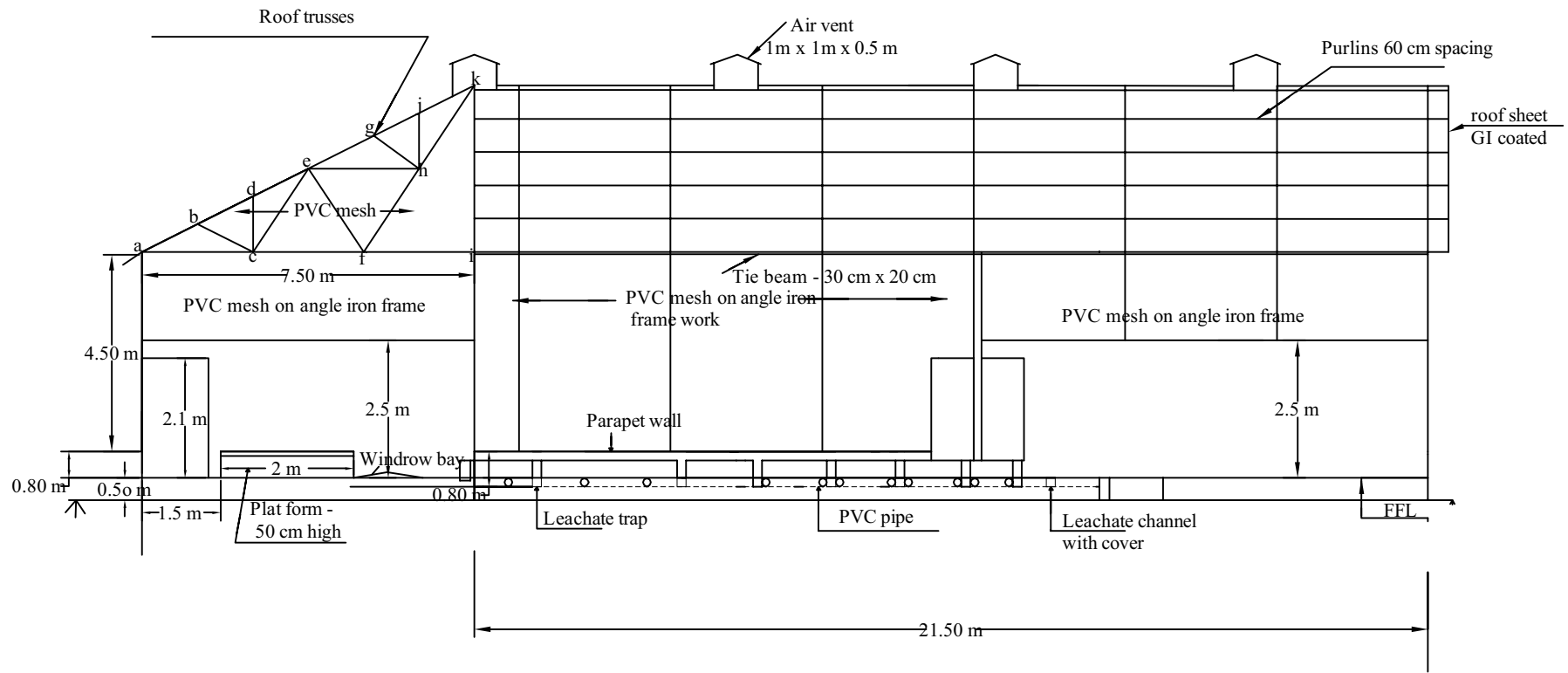

SECTIONAL ELEVATION OF VERMI COMPOST SHED AT AA1 & A1A2

NOT TO SCALE

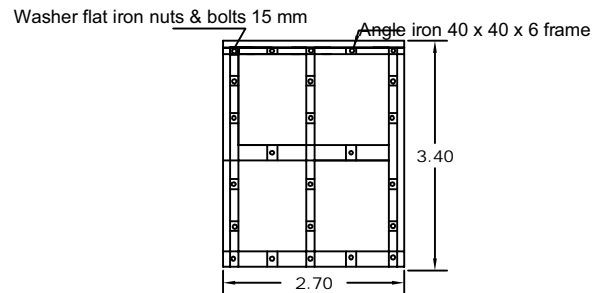

FIXING OF PVC MESH

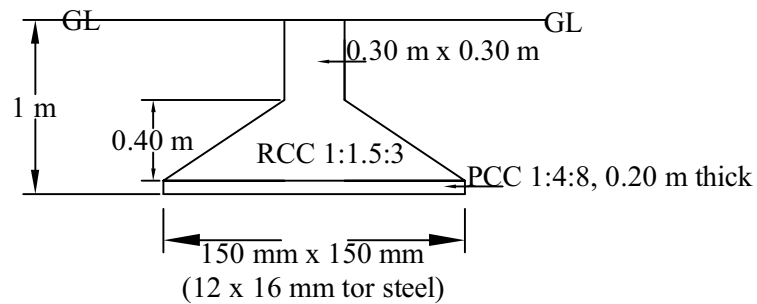

COLUMN FOOTING

Notes :

- a. Column - 30 cm x 30 cm
1:1.5:3 RCC
4 x 16 mm tor steel
 - Stirrup - 8 mm bar 20 cm c/c
 - b. Foundation between columns
RR - 60 cm x 60 cm
 - c. Basement
RR - 45 cm x 50 cm
 - d. Tie beam - 30 x 20 cm at the top of the column
- Reinforcement -
- Top - 2 x 12 tor steel
 - Bottom - 3 x 12 tor steel
 - Stirrup - 8 mm, 20 cm c/c

Truss details

- ak - 2Ls 75 x 75 x 6
- ai - 2Ls 50 x 50 x 6
- fk, ef, ce, eh - 2Ls 50 x 50 x 6
- bc,dc, gh, jh - 1L 50 x 50 x 6

CONSTRUCTION DETAILS OF VERMI / WINDROW COMPOST SHED

NOT TO SCALE

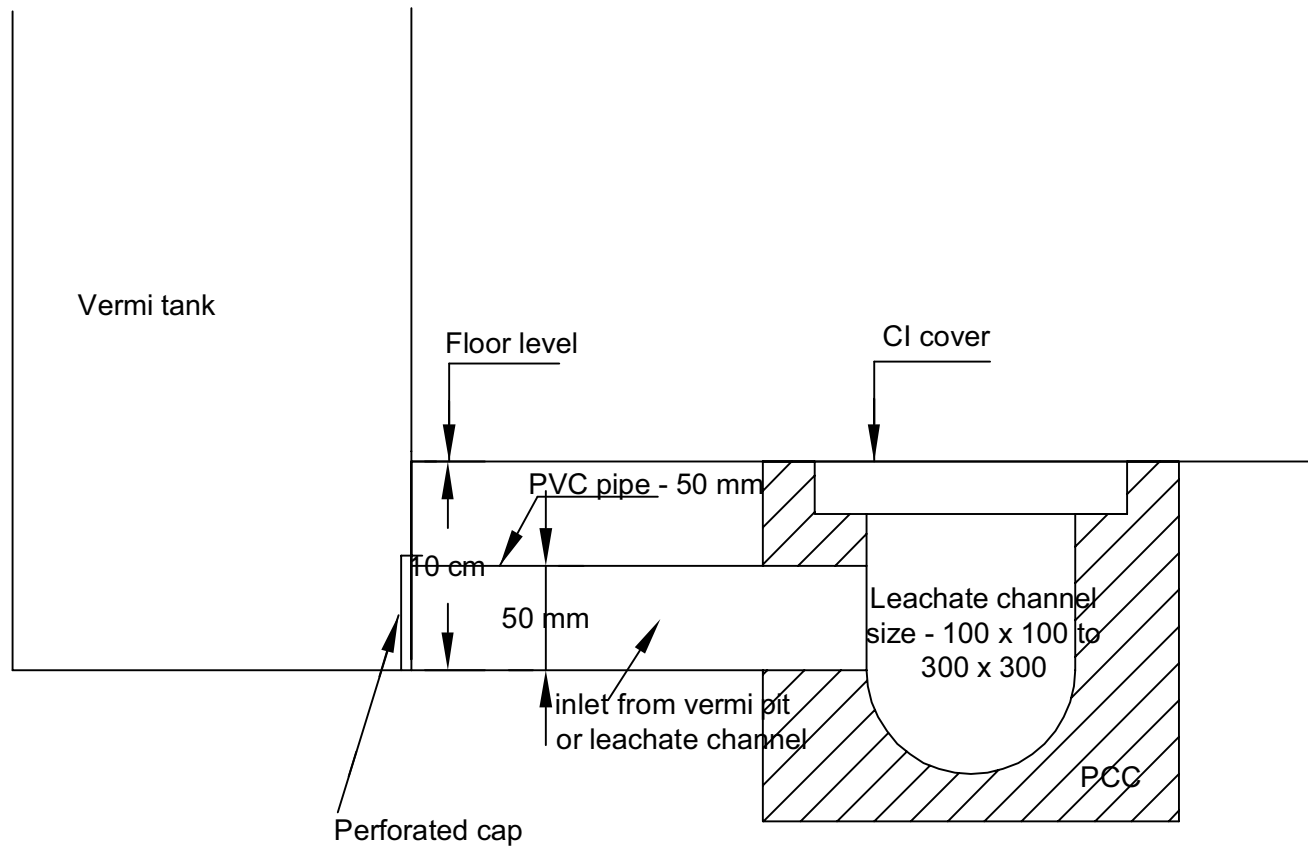

LEACHATE CHANNEL - MINIMUM SIZE 10 CM X 10 CM TO BE PROVIDED WITH ADEQUATE SLOPE (1 IN 100) FOR VERMI COMPOST PLANT

NOT TO SCALE

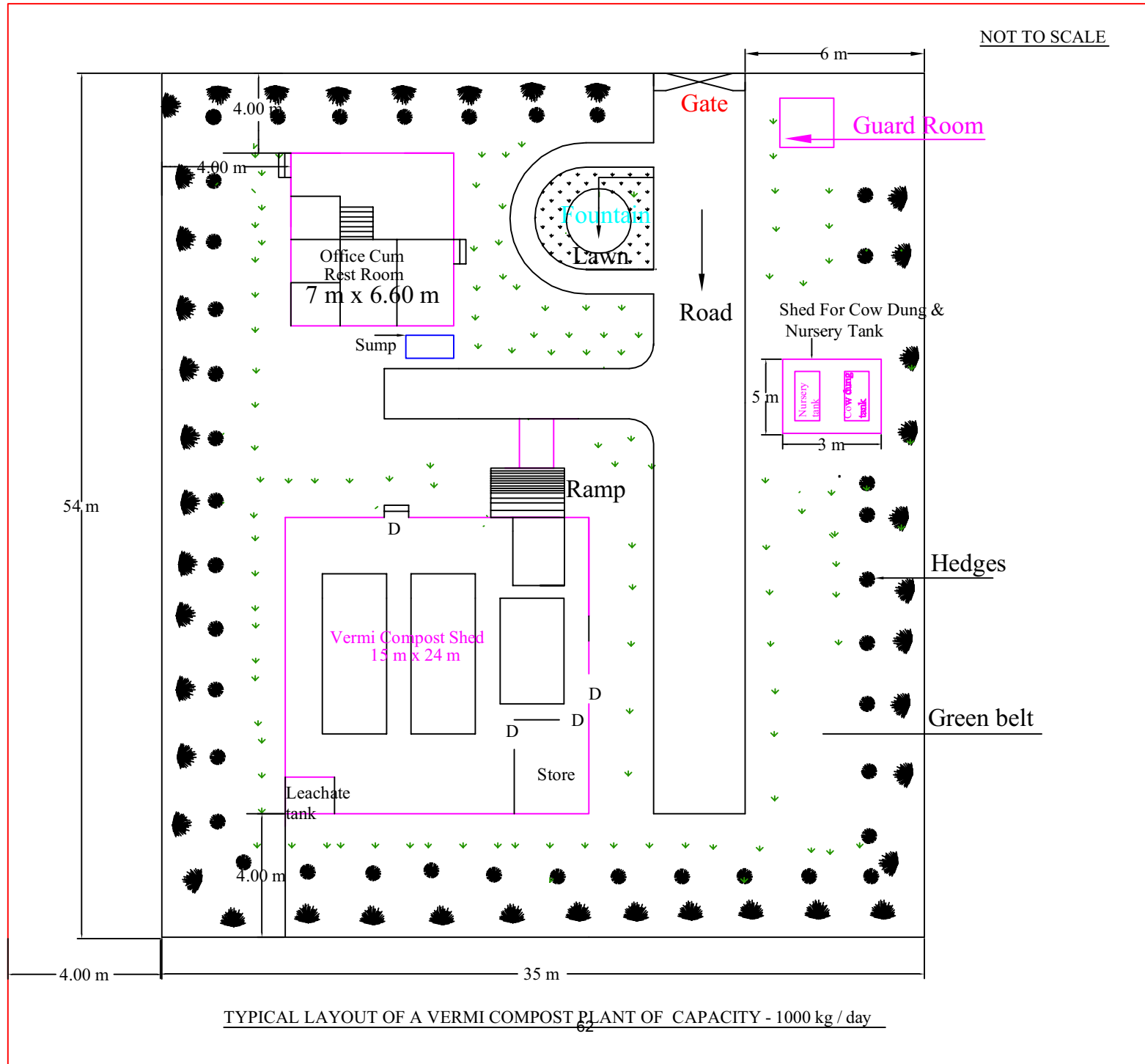

TYPICAL LAYOUT OF A VERMI COMPOST PLANT OF CAPACITY - 1000 kg / day

NOT TO SCALE

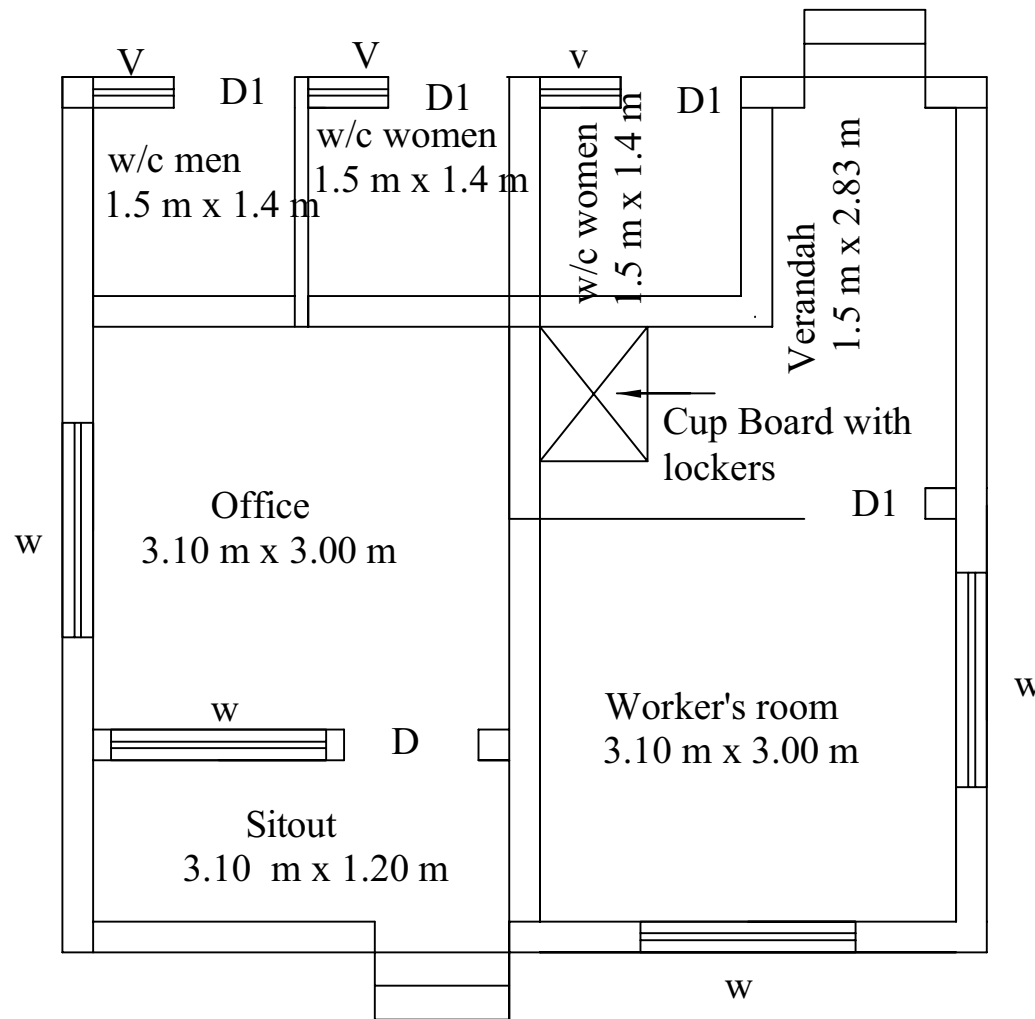

Index

Sl. No.	Item	Size
1	D	1.00 x 2.10
2	D1	0.90 x 2.10
3	W	1.60 x 1.50
4	V	0.60 x 1.00

Office room cum Rest room with wash area

NOT TO SCALE

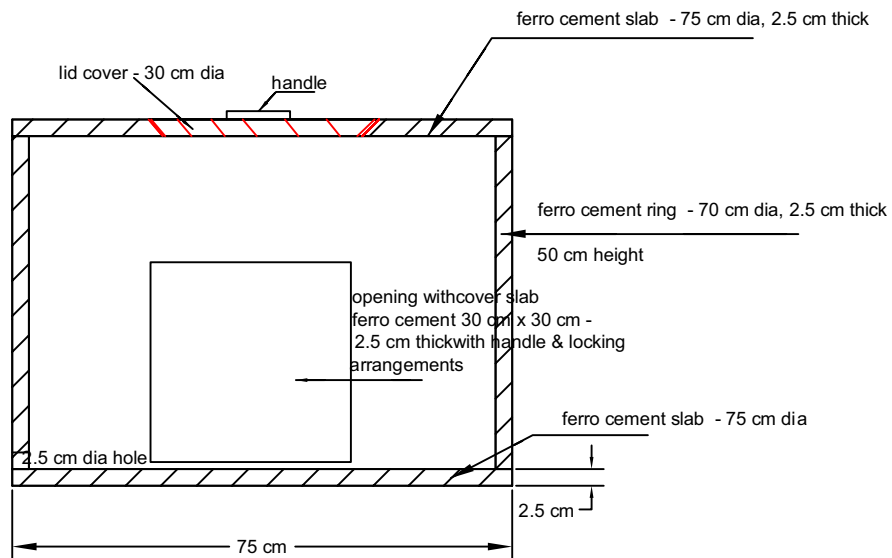

SECTIONAL ELEVATION - ANAEROBIC COMPOSTING UNIT

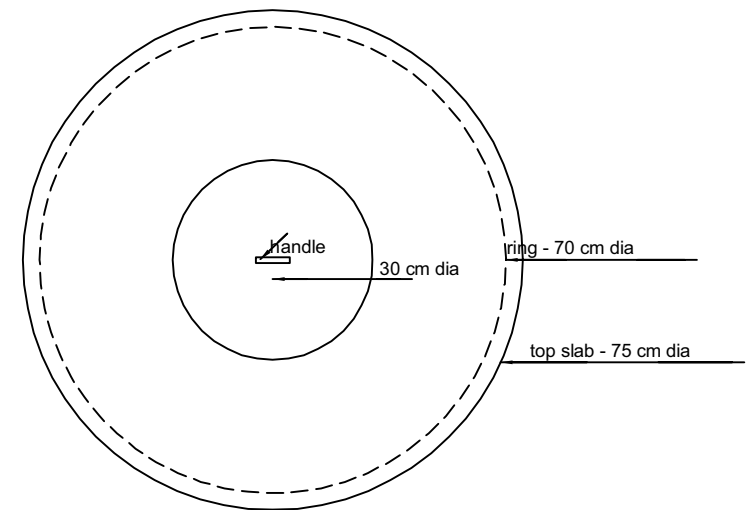

PLAN - ANAEROBIC COMPOSTING UNIT

NOT TO SCALE

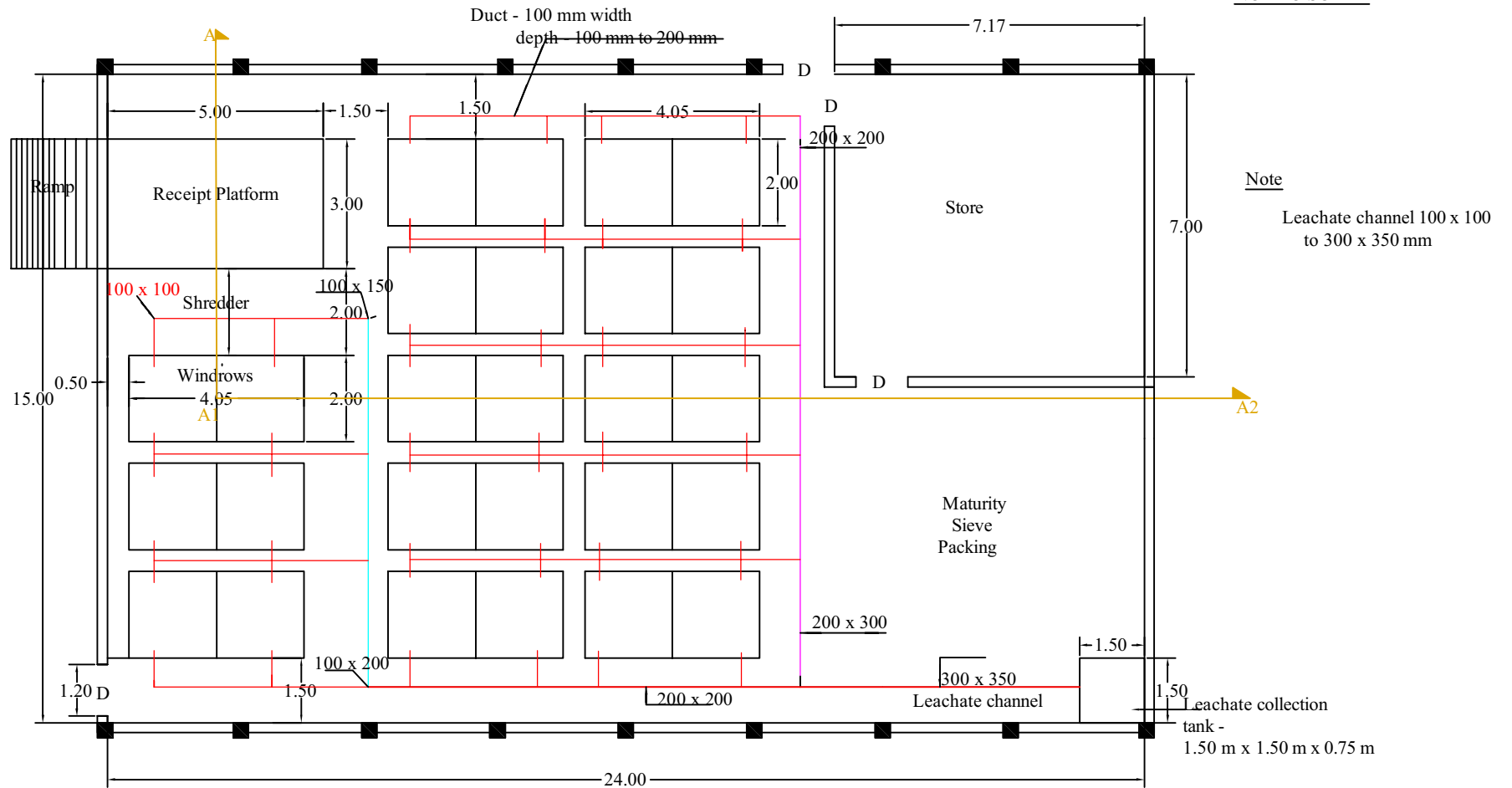

Note

Leachate channel 100 x 100 to 300 x 350 mm

LAYOUT OF A TYPICAL WINDROW COMPOST SHED -
3 TONNE PER DAY CAPACITY

NOT TO SCALE

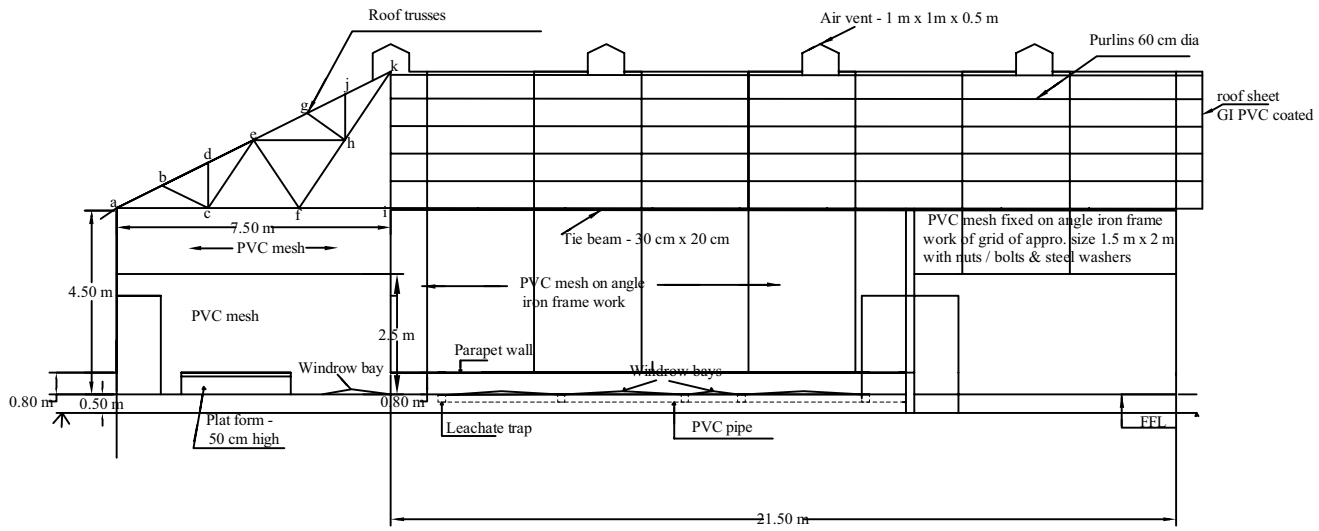

SECTIONAL ELEVATION OF WINDROW COMPOST PLANT AT AA1 & A1A2

SKETCH NO. 8

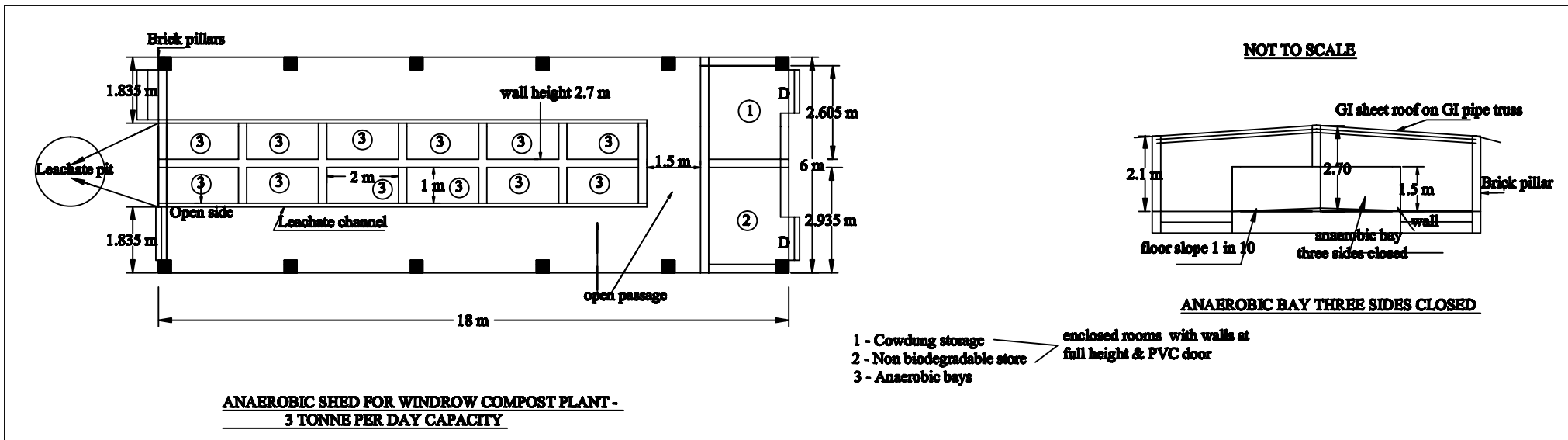

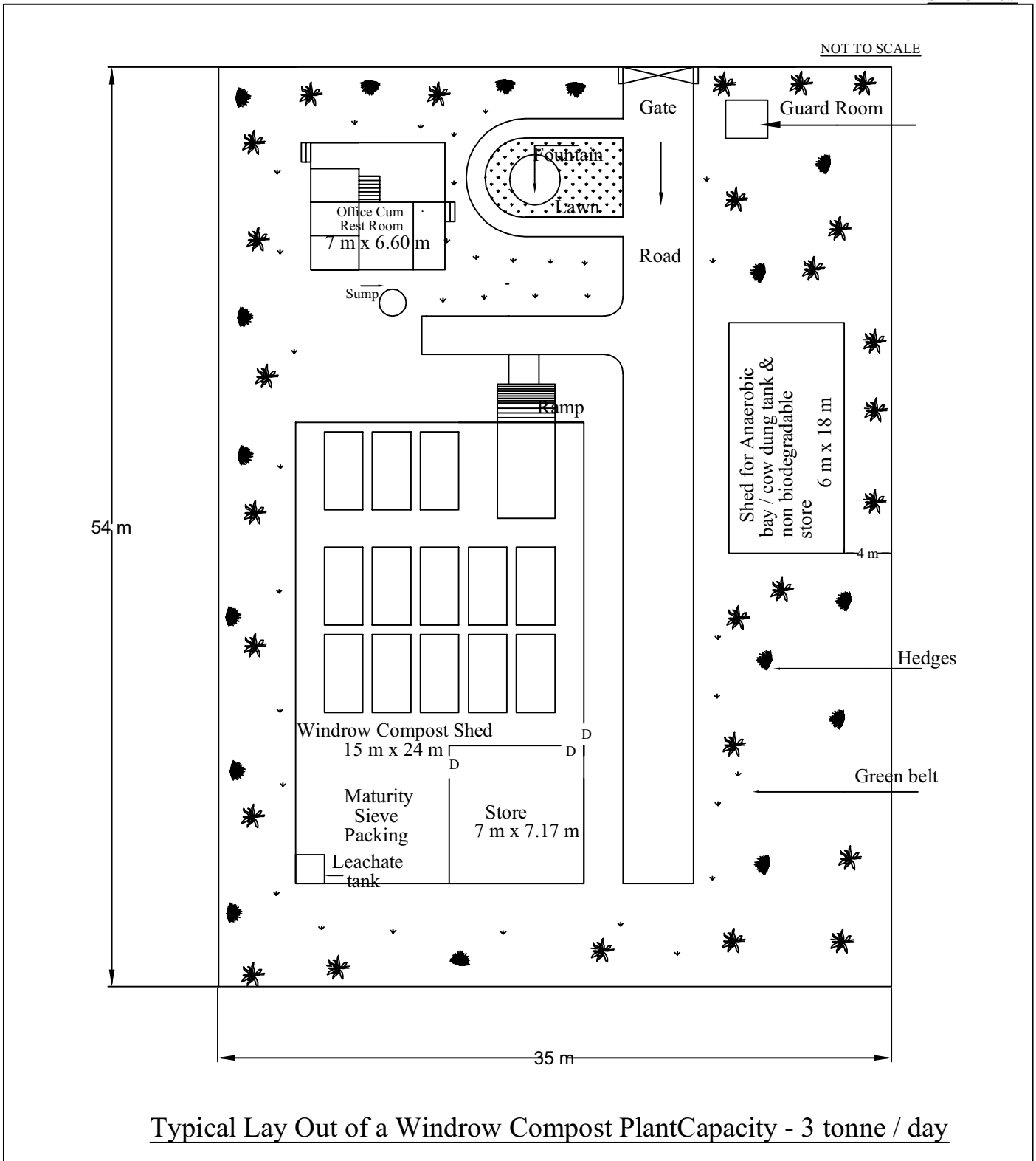

SKETCH NO.10

NOT TO SCALE

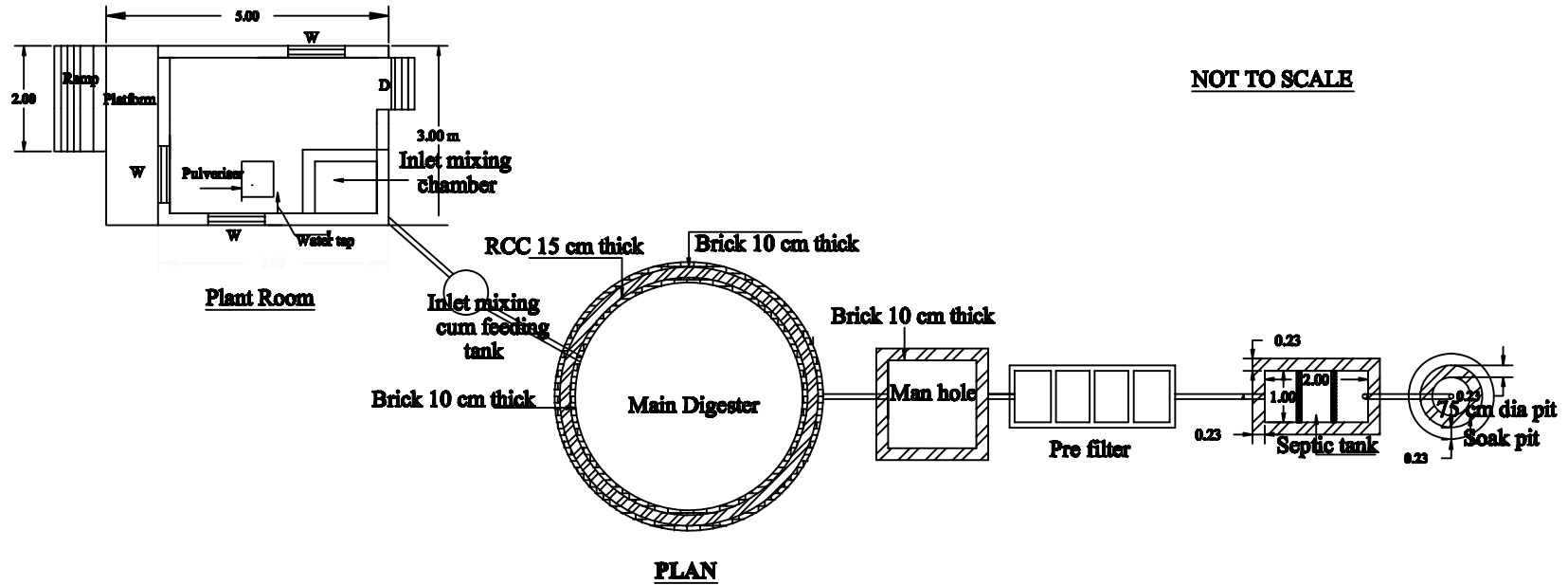

TYPICAL LAYOUT OF A BIOGAS PLANT OF CAPACITY UPTO 600 kg/ day (FLOATING TYPE)

NOT TO SCALE

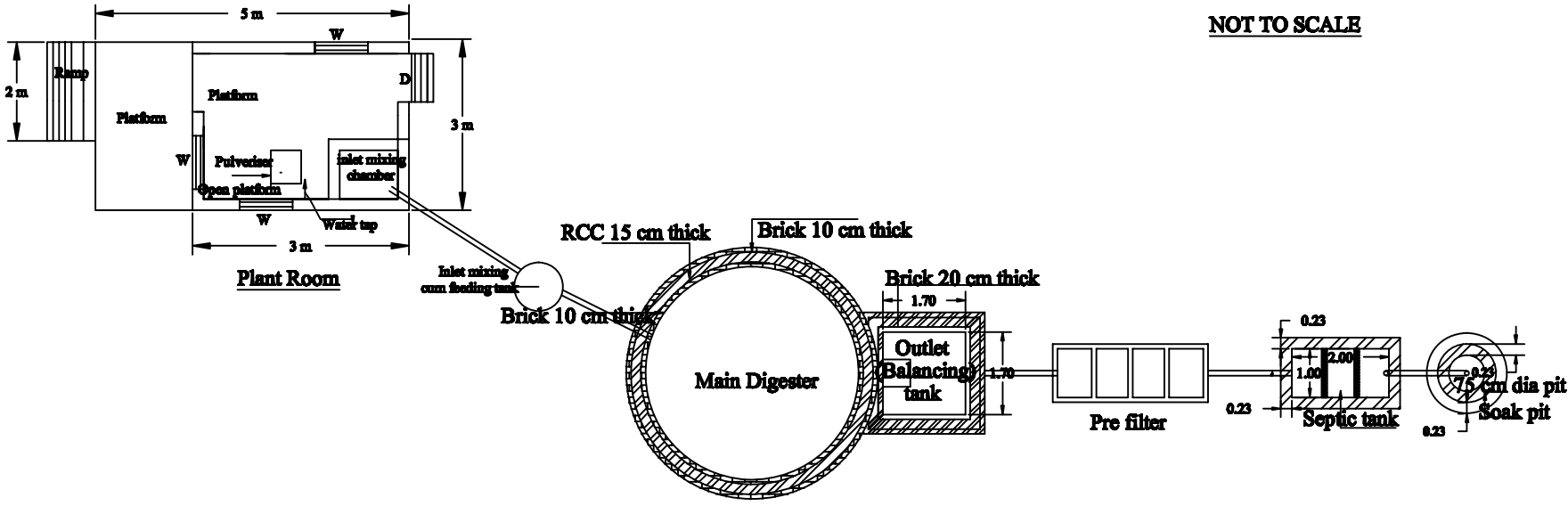

PLAN

TYPICAL LAYOUT OF A BIOGAS PLANT OF CAPACITY UPTO 600 kg/ day (FIXED DOME)

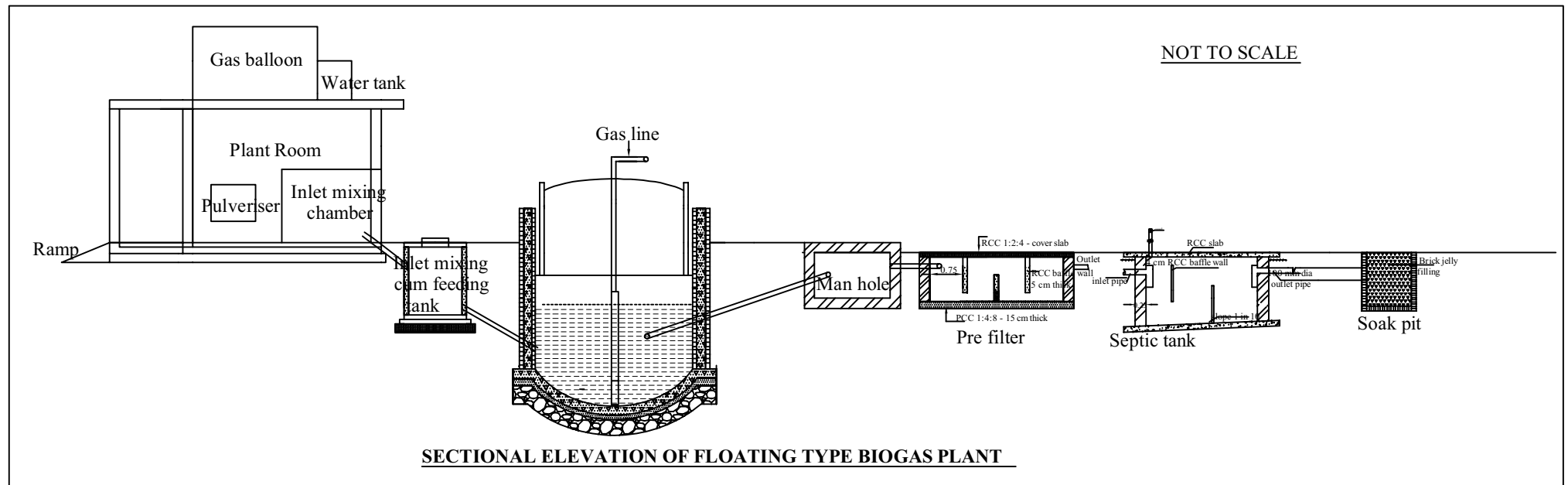

NOT TO SCALE

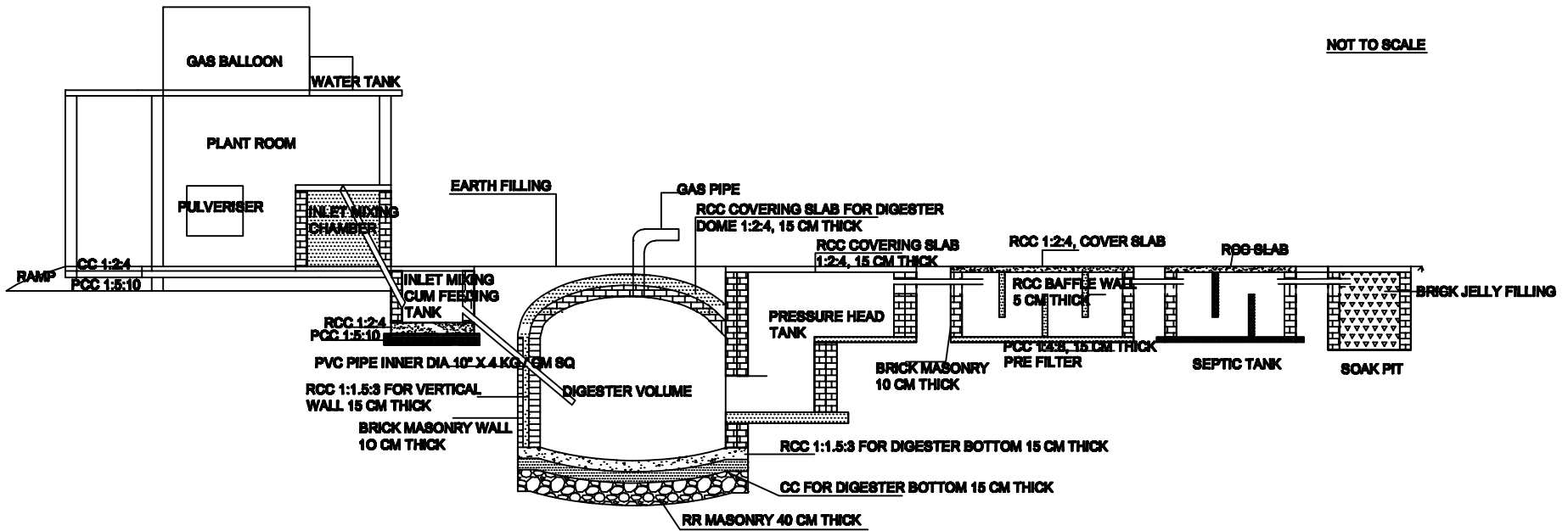

SECTIONAL ELEVATION OF BIO GAS PLANT OF CAPACITY 600 KG/DAY (FIXED DOME)